

Canon Gift box D (Brown) : Assembly Instructions

Canon ® is a registered trademark of Canon Inc. © Canon Inc. © Yukiko Tanikoshi



You will need

scissors, paste, a used ballpoint pen (tracing along the fold lines makes them easier to fold)

Explanation of Symbols

▲ Numbered glue tabs

Glue the parts together in the order indicated by the numbers.



[Caution]

Glue, scissors and other tools may be dangerous to young children so be sure to keep them out of the reach of young children.

Assembly procedure

— Cut line - - - Mountain fold - · - · Valley fold — Slot

STEP

1 Assemble the sides of the box

Fold along all the dotted lines on parts [2] to [6].

Glue parts [3] [4] [5] and [6] to part [2].

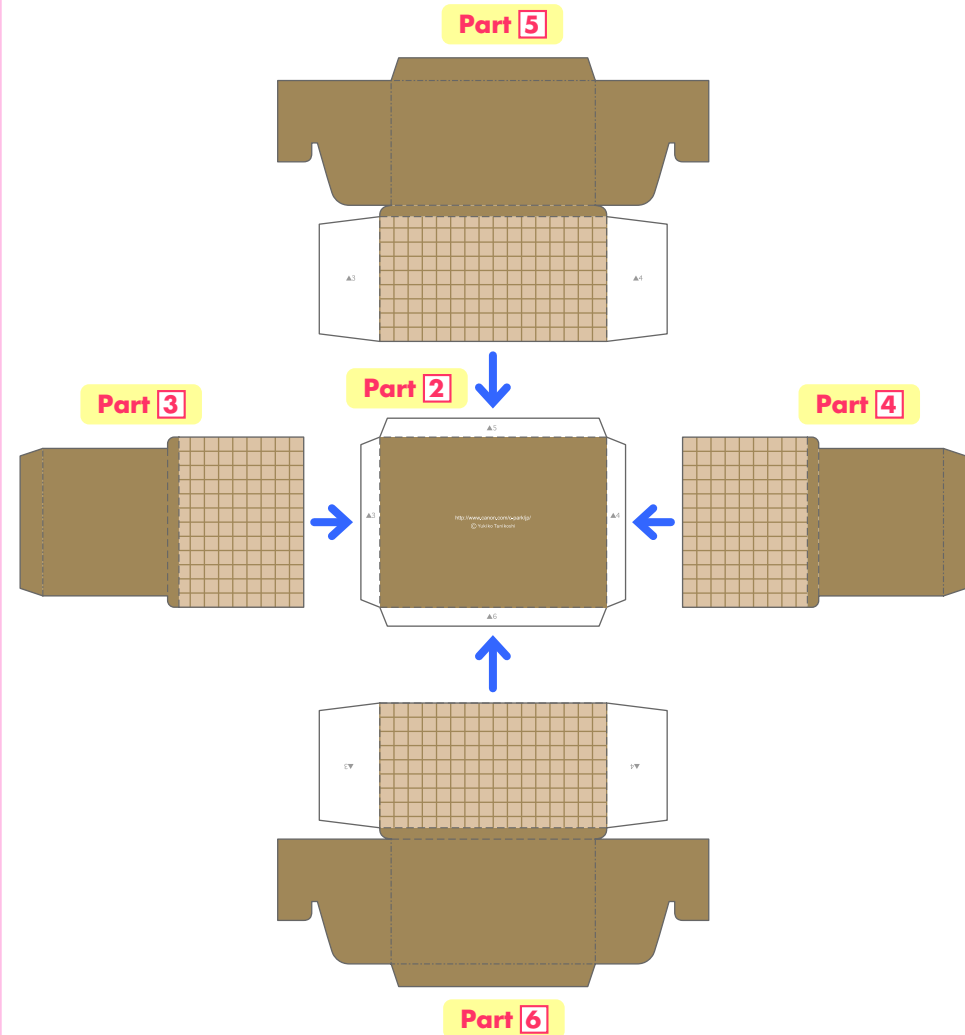

Canon Gift box D (Brown) : Assembly Instructions

Canon® is a registered trademark of Canon Inc. © Canon Inc. © Yukiko Tanikoshi

Assembly procedure

★STEP★

2 Assemble the box

Assemble the base and sides of the box you made in step 1.

Hook these parts of parts 5 and 6 together.

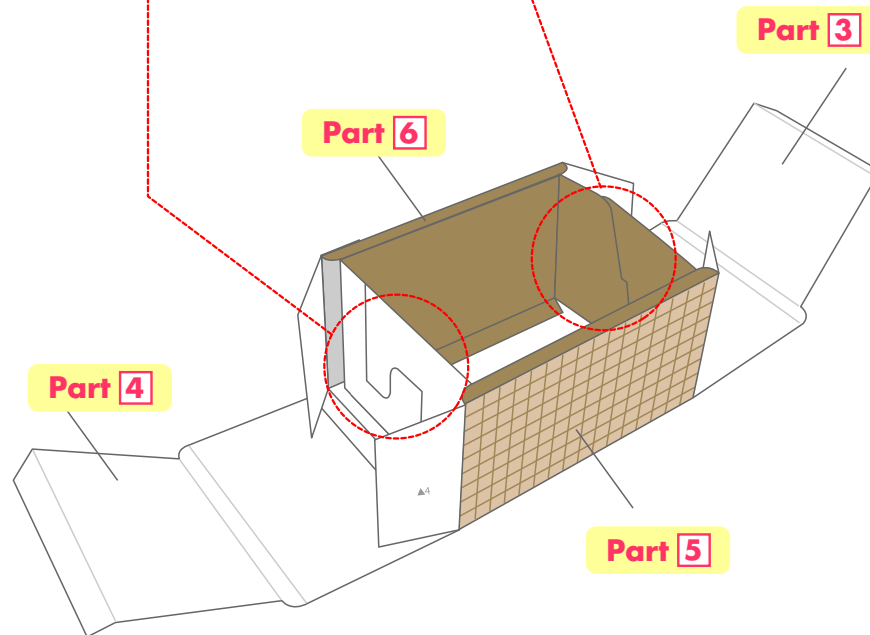

Put glue on the indicated areas of parts 5 and 6, and attach them to part 3. Fold them inside the box.

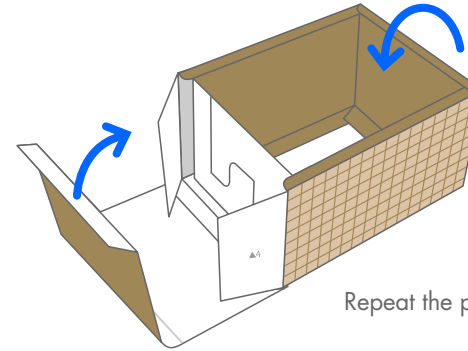

Repeat the process for part 4.

Cover the entire back surface of part 1 with glue, and attach it to the base of the box.

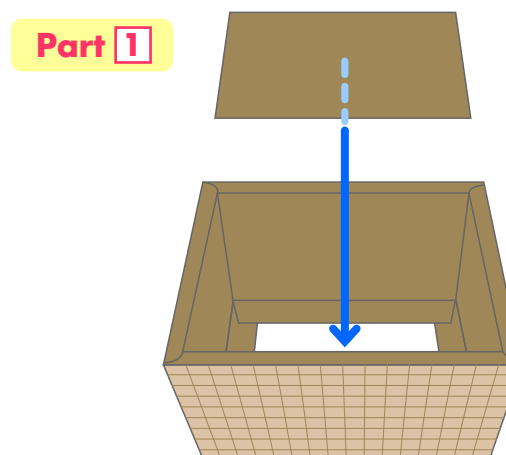

Canon Gift box D (Brown) : Assembly Instructions

Canon® is a registered trademark of Canon Inc. © Canon Inc. © Yukiko Tanikoshi

Assembly procedure

STEP 3 Assemble the lid

Fold along all the dotted lines on parts 8 to 12.
Glue parts 9, 10, 11 and 12 to part 8.

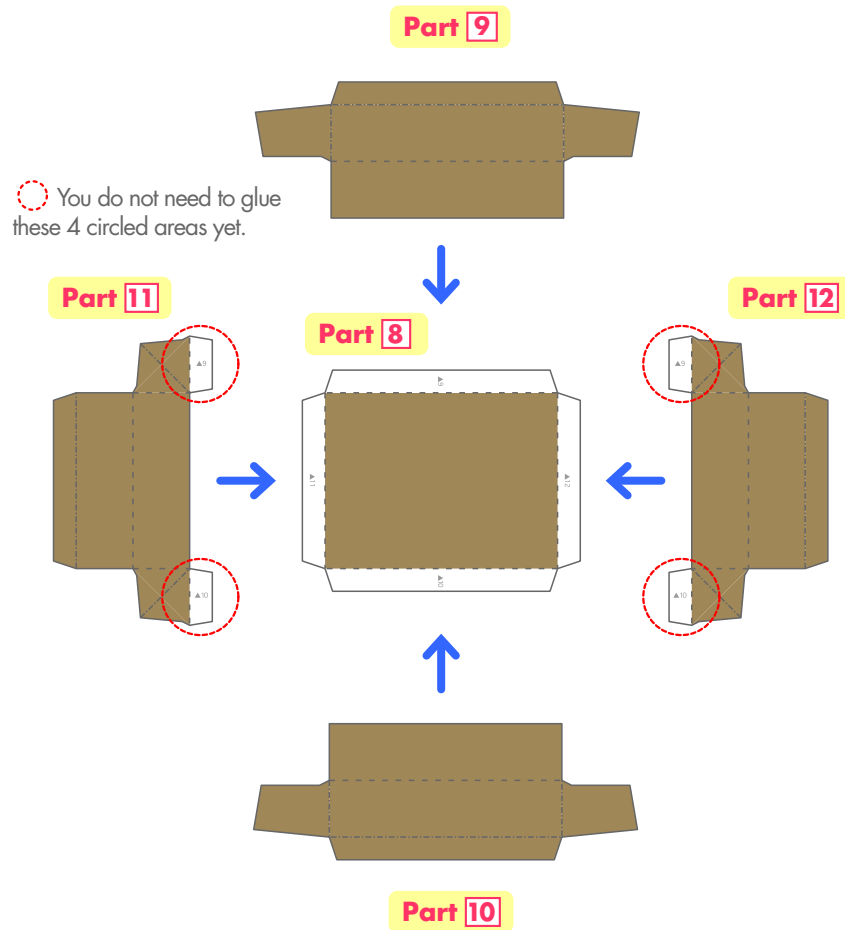

Take the 4 areas you left unglued and glue them to the inner side of parts 10 or 11 as appropriate.

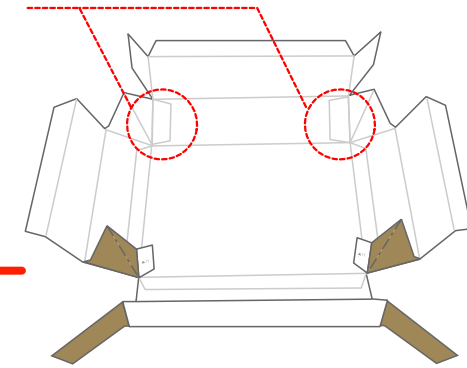

Fold parts 10 and 11 inside.

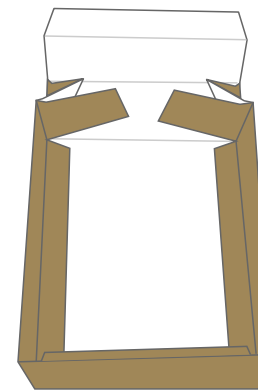

Cover the entire back surface of part 7 with glue, and attach it to the underside of the lid.

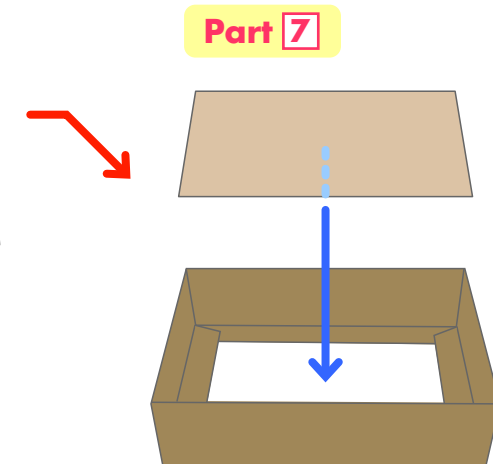

Canon Gift box D (Brown) : Assembly Instructions

Canon® is a registered trademark of Canon Inc. © Canon Inc. © Yukiko Tanikoshi

Assembly procedure

STEP 4 Finishing the box

Fit the lid you made in step 3 onto the box from step 2, and your project is complete!

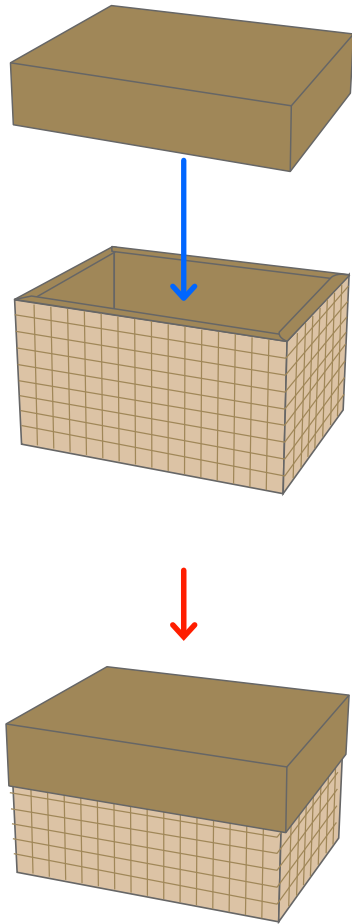

STEP 5 Making the Ribbon

Put glue on the back of part 13, and glue it in half so that the colored side faces out. Cut out the ribbon along the lines.

Part 13

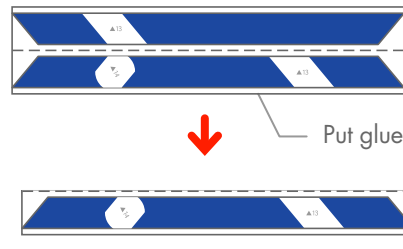

Put glue on the back.

Twist the ribbon as shown in the diagram, and glue it down.

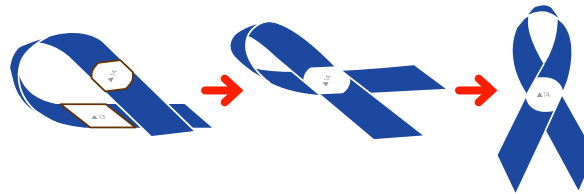

Attach part 14 (sticker) to the ribbon.

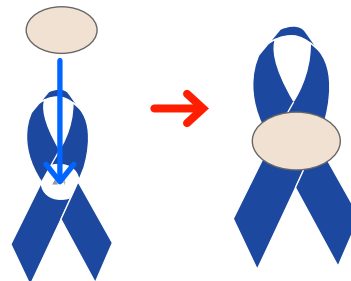

STEP 6 Making the Card

Glue the front and back pages of the card from part 15 together and fold in half to complete your card.

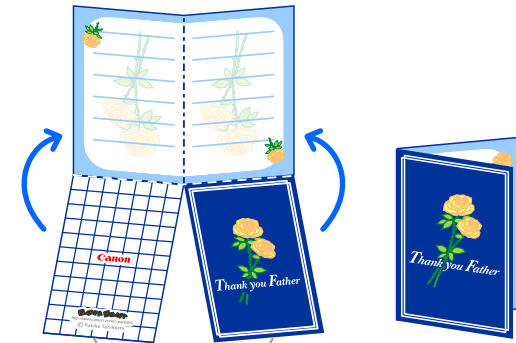

Put glue on the back.

Attach the ribbon to the box, and attach the card.

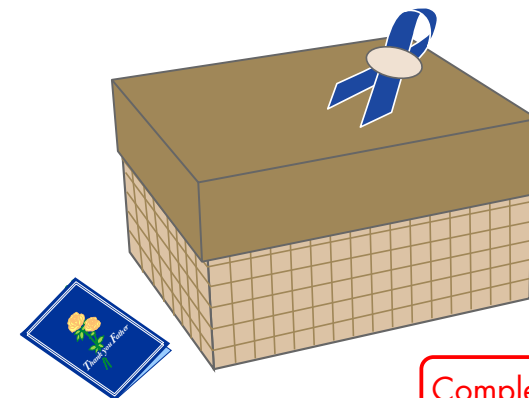

Completed