

ULTRA REALISTIC PAPER CRAFT

MT-10**Assembly Instructions
vol.2****Exhaust Pipe / Frame / Step / Rear Arm
Seat / Seat Cowl**

Please follow these assembly instructions, cross-checking the part numbers on the parts sheet. Assemble all the parts from **vol.1** to **vol.3**.

A realistic recreation of the **MT-10**. will be the result.

This file provides assembly instructions. Please download the parts data separately.



We recommend to print out the parts data on A4 inkjet printer paper for paper craft, sturdy paper or card.

1 To begin

Tools and materials needed

-Ruler - scissors - blade cutter or "Exacto-knife" - awl or other pointed tool - Embospen - Transer (for making a folding crease) - Felt pen - Pin set - Glue - Hand towel (for cleaning your fingers) - dictionary or other heavy book (to press the papers flat).

Items of Caution

*Take care when using sharp or pointed objects or when using bladed cutting tools. Place a heavy sheet of paper under the paper you want to cut.

*Use glue and other adhesives only in well-ventilated areas.

*When printing, use a slightly reduced font size. There may be differences in dimensions, depending on the type of printer used.

2 How to assemble

*Follow the working method and markings carefully.

*Cut carefully along the outer line with cutting blade, Exacto-knife or scissors.

One-point Advise

*Cut carefully with cutting blade, Exacto-knife or scissors.

*For folding parts, first use an awl or other pointed tool to make a light crease along the dotted or solid line. This will make the folds straight. Avoid making strong creases, as this will cause the paper to tear.

*As an adhesive, white wood glue is recommended. Avoid over application as this may cause the paper to wrinkle.

*Before beginning assembly, test adhesive amounts on extra paper.

*Occasionally, white spots will be apparent on folds and cuts. Use a marker or pencil to fill in these spots. It is recommended that this be done after each stage of assembly because coloring becomes more difficult once parts are assembled.

Basic working method and markings

Solid lines

Fold along these lines.

The printed surface should be on the outside of the folded shape.

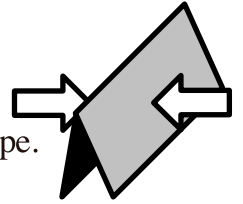

Broken lines

Fold along these lines.

The printed surface should be on the inside of the folded shape.

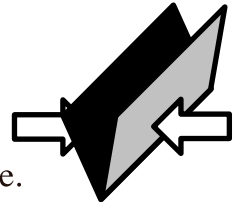

Dotted lines

Cut along these lines.

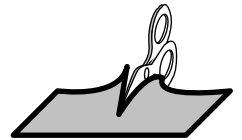

Do not fold or cut the parts marked X.

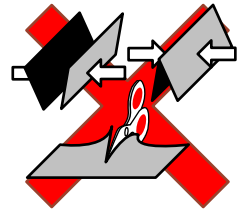

Cut out parts marked with an asterisk(*).

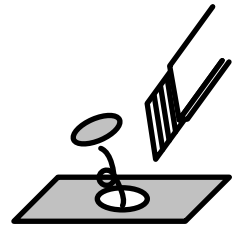

Red dots are the reference positions for gluing surfaces.

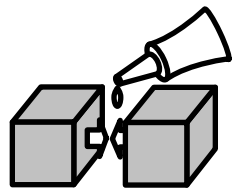

Please glue them by aligning the red and red/blue and blue parts if they are marked on the paper.

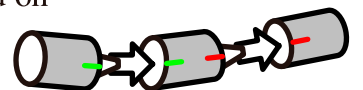

These shaded areas indicate where glue should be applied.

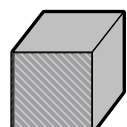

3 Assembly of the Exhaust Pipes

Please refer to the "Basic working method and markings" symbol chart on Page 2 to assemble each part.



Exhaust Pipes A

*Assemble both sides. The diagram shows the left side. The number inside the () is for the right side.

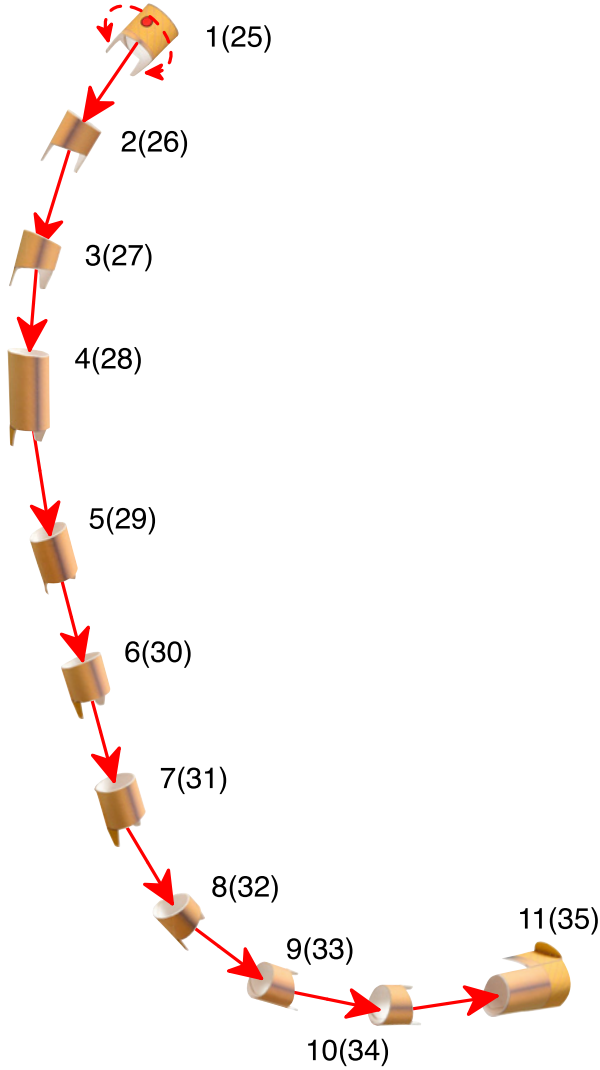

Exhaust Pipes B

*Assemble both sides. The diagram shows the left side. The number inside the () is for the right side.

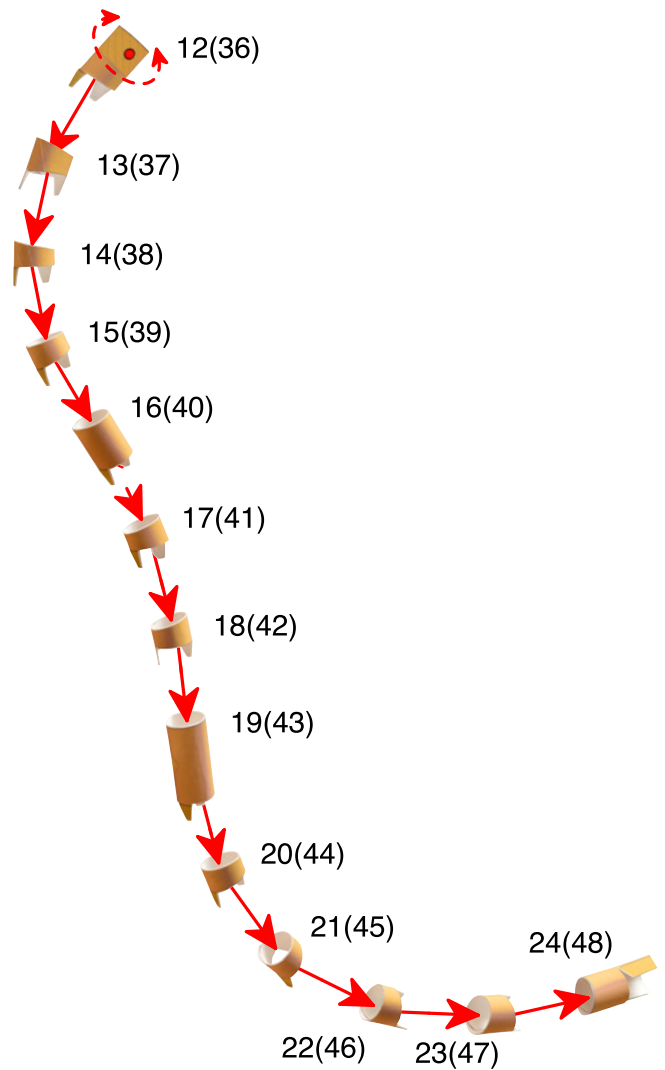

Exhaust Pipes C

*Assemble both sides. The diagram shows the left side.

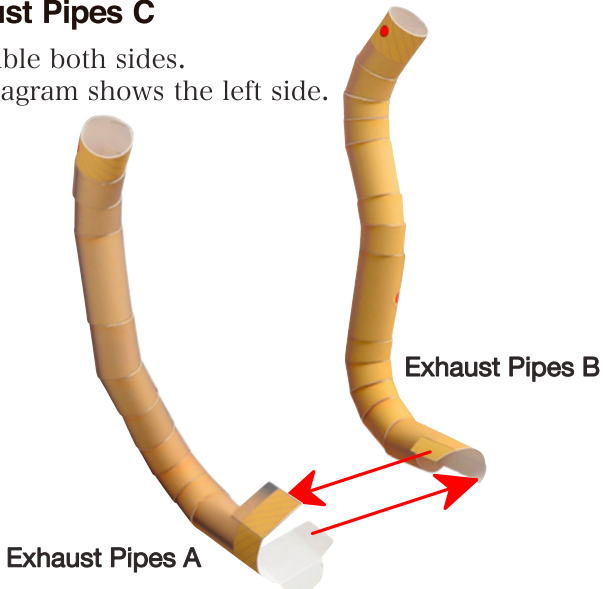

Exhaust Pipes D

*Assemble both sides. The diagram shows the left side. The number inside the () is for the right side.

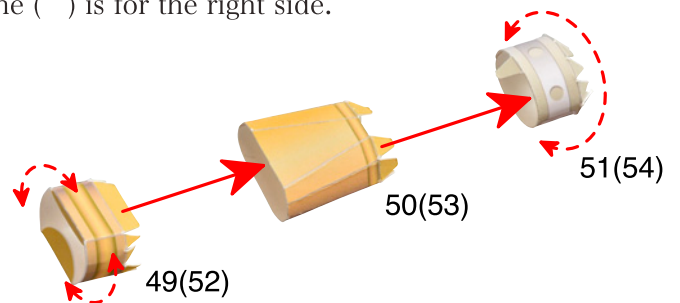

Please refer to the "Basic working method and markings" symbol chart on Page 2 to assemble each part.



Exhaust Pipes E

*Assemble both sides. The diagram shows the left side. The number inside the () is for the right side.

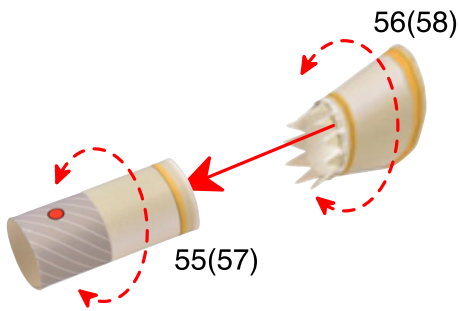

Exhaust Pipes F

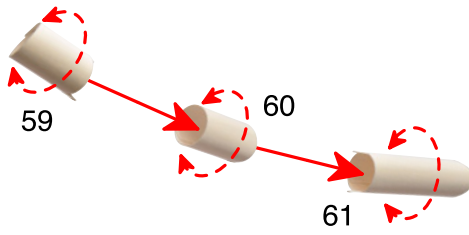

Exhaust Pipes G

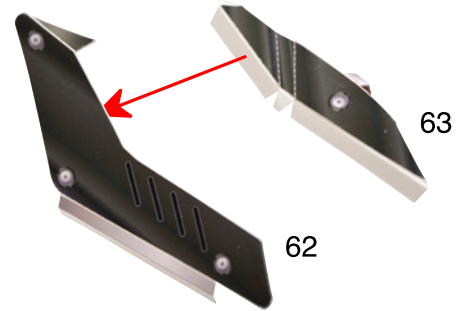

Exhaust Pipes H

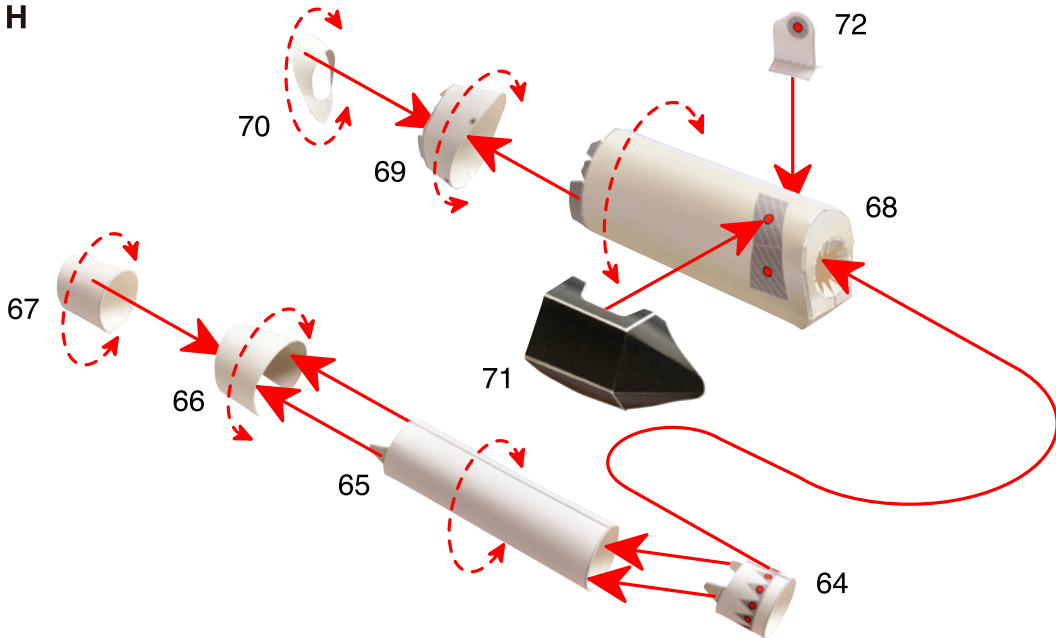

Exhaust Pipes I

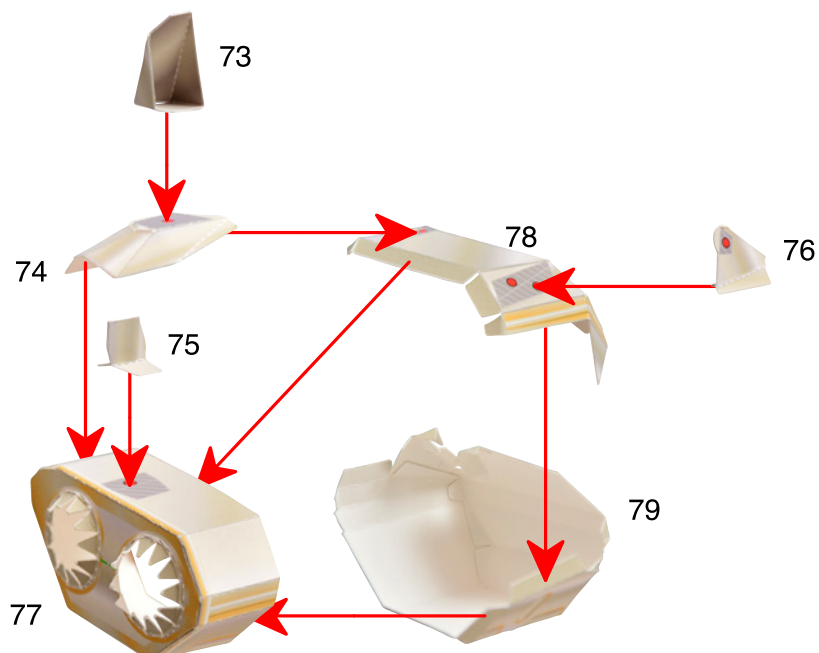

Please refer to the "Basic working method and markings" symbol chart on Page 2 to assemble each part.

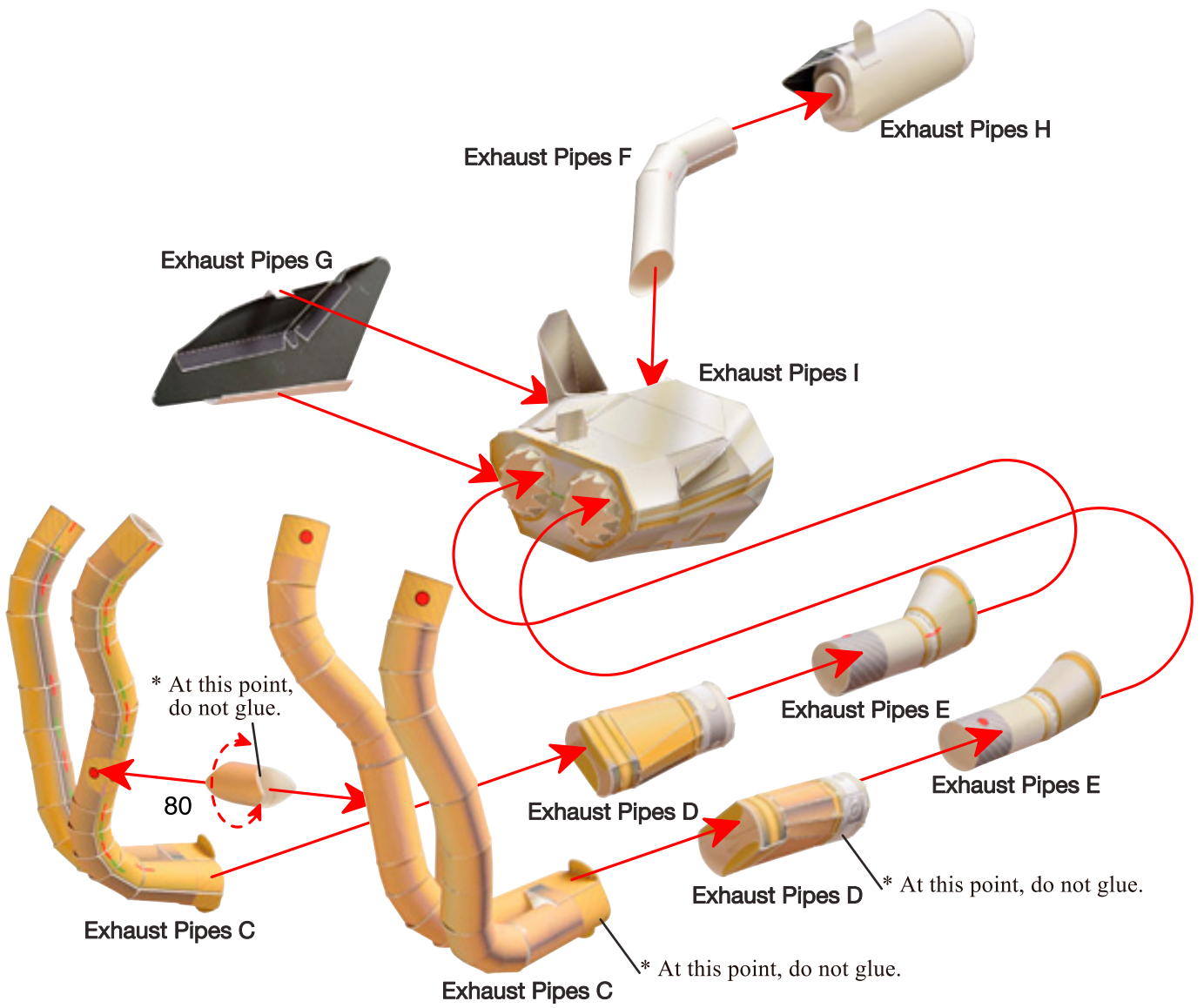

< Reference photo >



3 Assembly of the Frame1

Please refer to the "Basic working method and markings" symbol chart on Page 2 to assemble each part.

Fold or Curve

Glue

Insert

Gluing surfaces

Frame1A

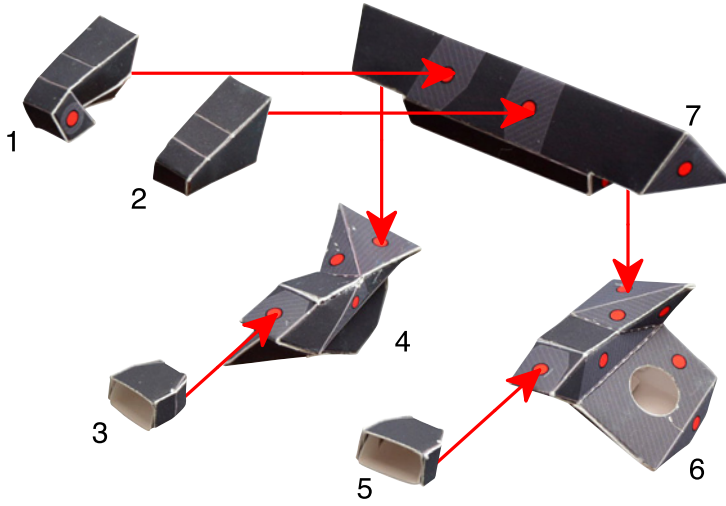

Frame1B

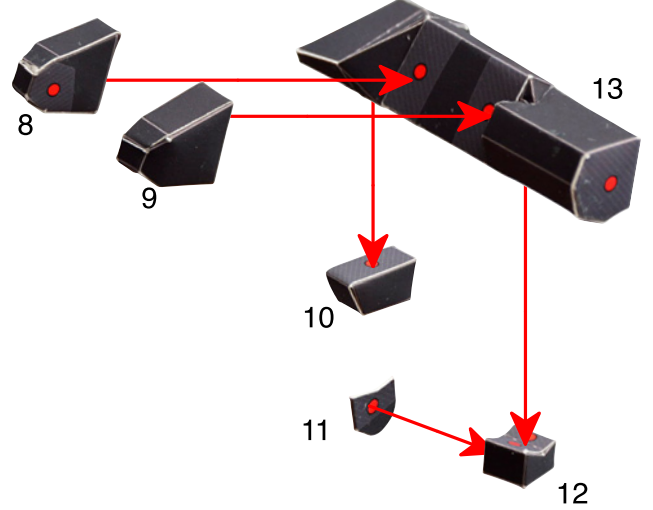

Frame1C

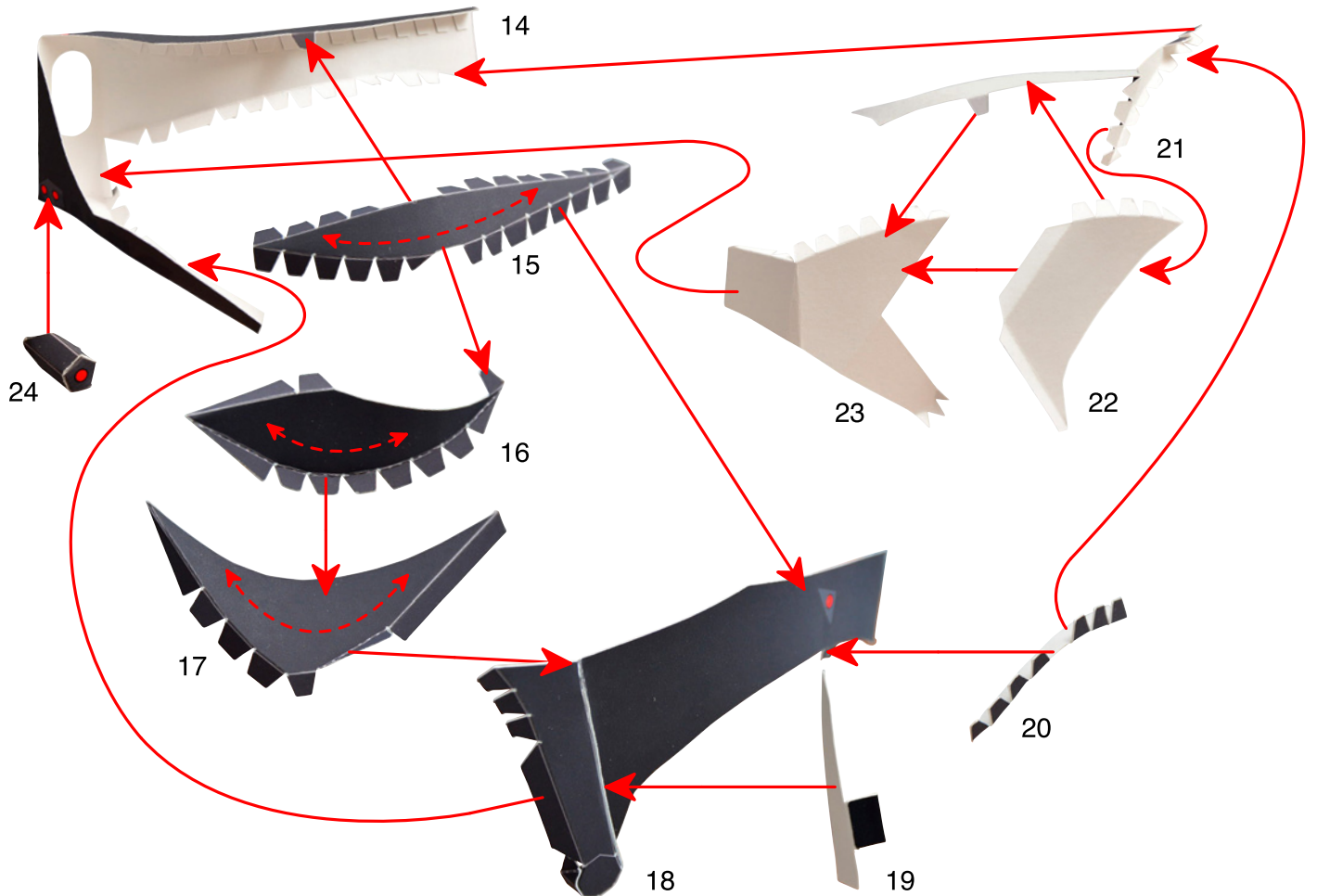

Please refer to the "Basic working method and markings" symbol chart on Page 2 to assemble each part.



Frame1D

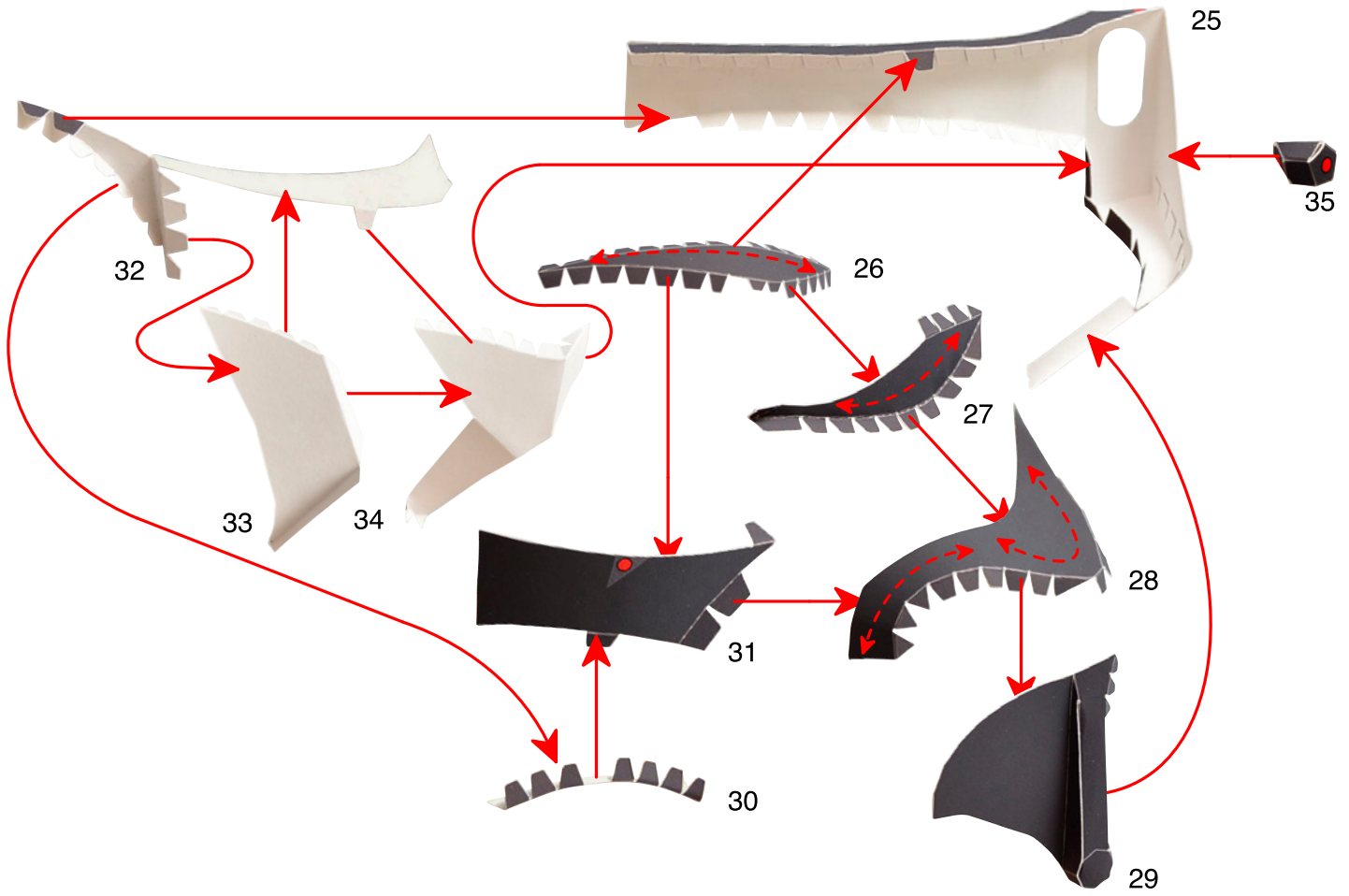

Frame1E

*Assemble both sides. The diagram shows the right side. The number inside the () is for the left side.

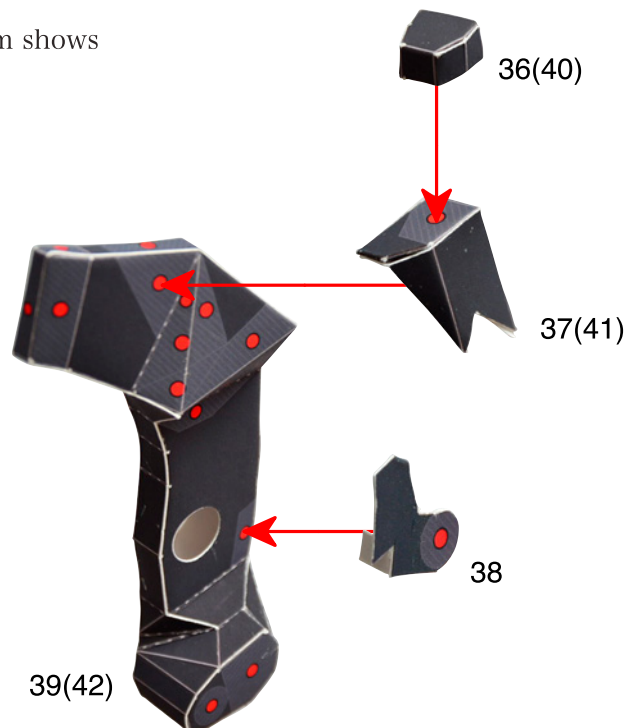

Please refer to the “Basic working method and markings” symbol chart on Page 2 to assemble each part.

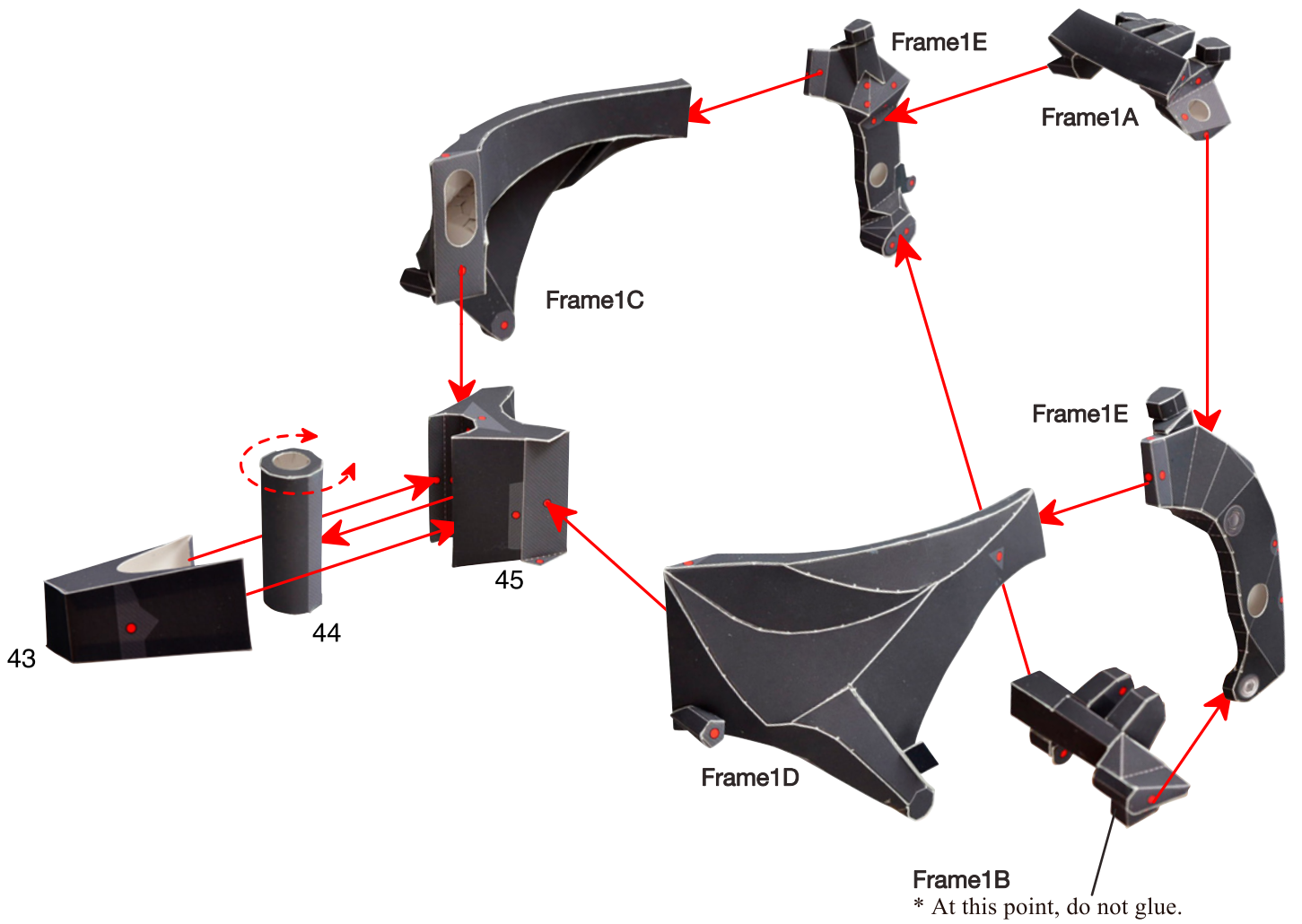

< Reference photo >



3 Assembly of the Frame2

Please refer to the "Basic working method and markings" symbol chart on Page 2 to assemble each part.

 Fold or Curve

 Glue

 Insert

 Gluing surfaces

Frame2A

*Assemble both sides. The diagram shows the left side. The number inside the () is for the right side.

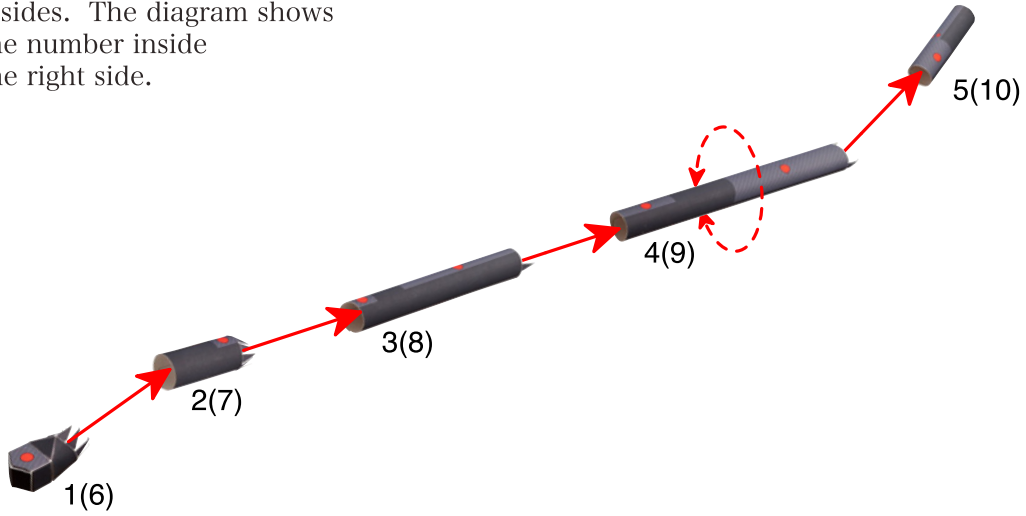

Frame2B

*Assemble both sides. The diagram shows the left side. The number inside the () is for the right side.

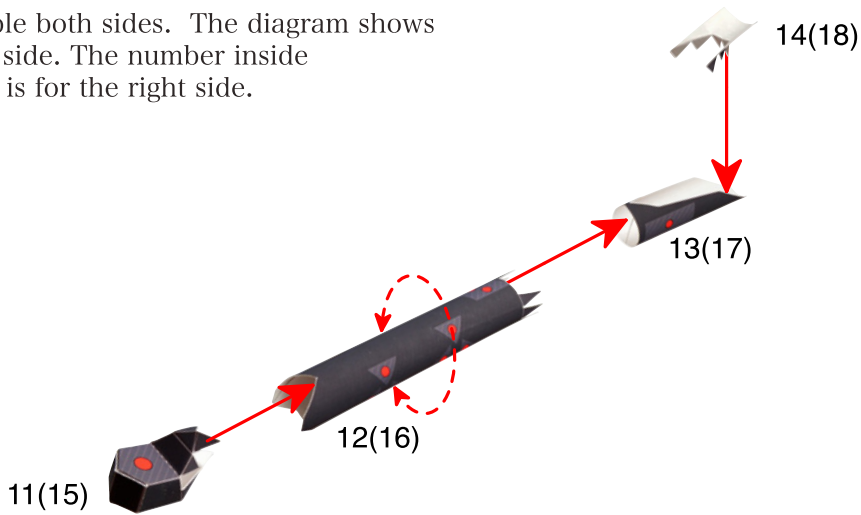

Frame2C

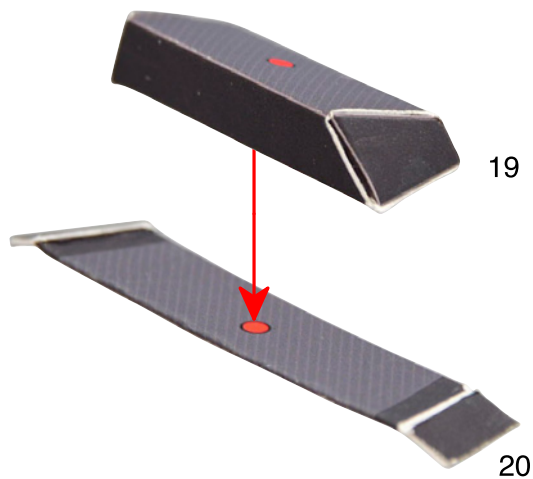

Please refer to the "Basic working method and markings" symbol chart on Page 2 to assemble each part.

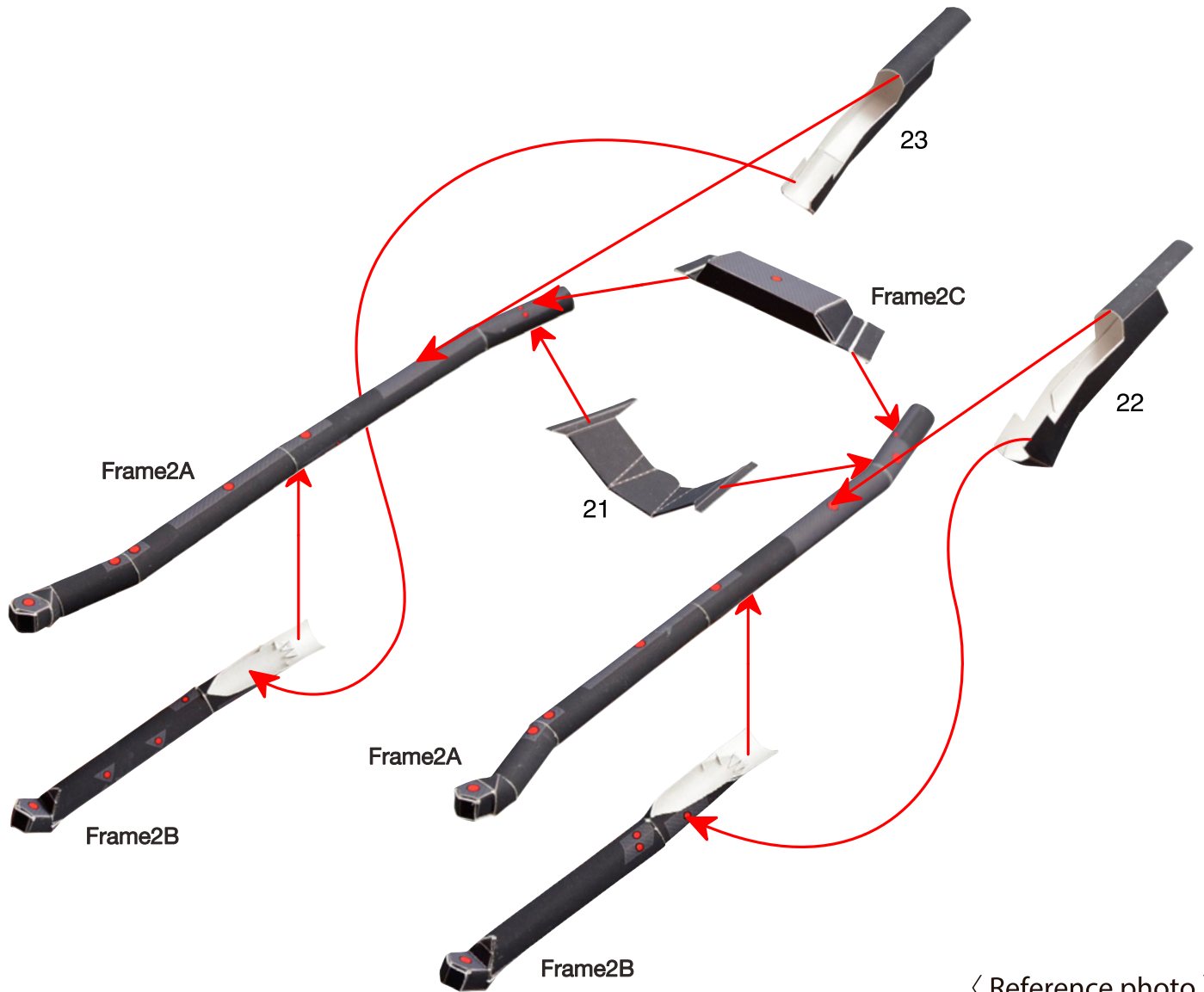

〈 Reference photo 〉



3 Assembly of the Rear Arm

Please refer to the "Basic working method and markings" symbol chart on Page 2 to assemble each part.



Rear Arm A

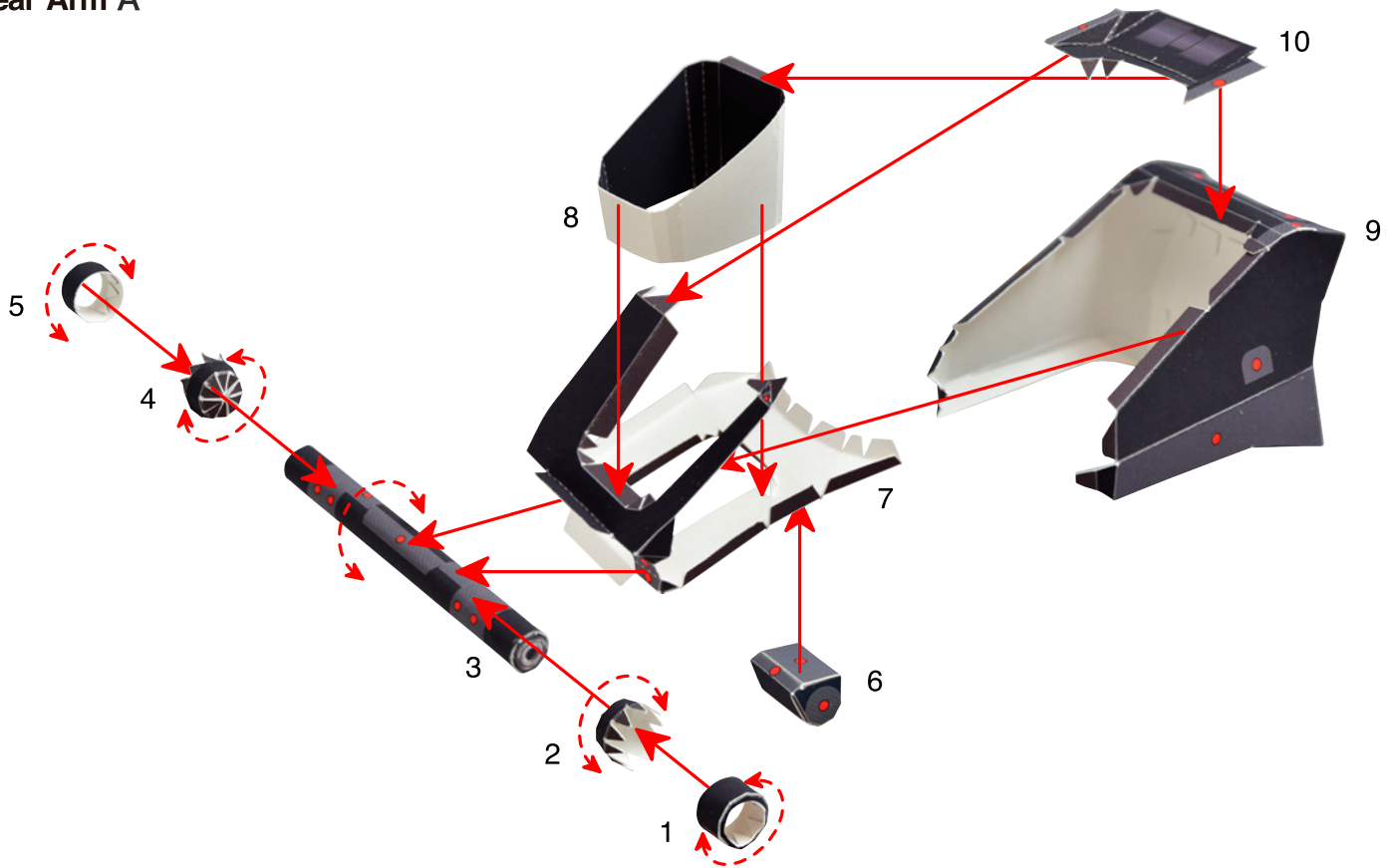

Rear Arm B

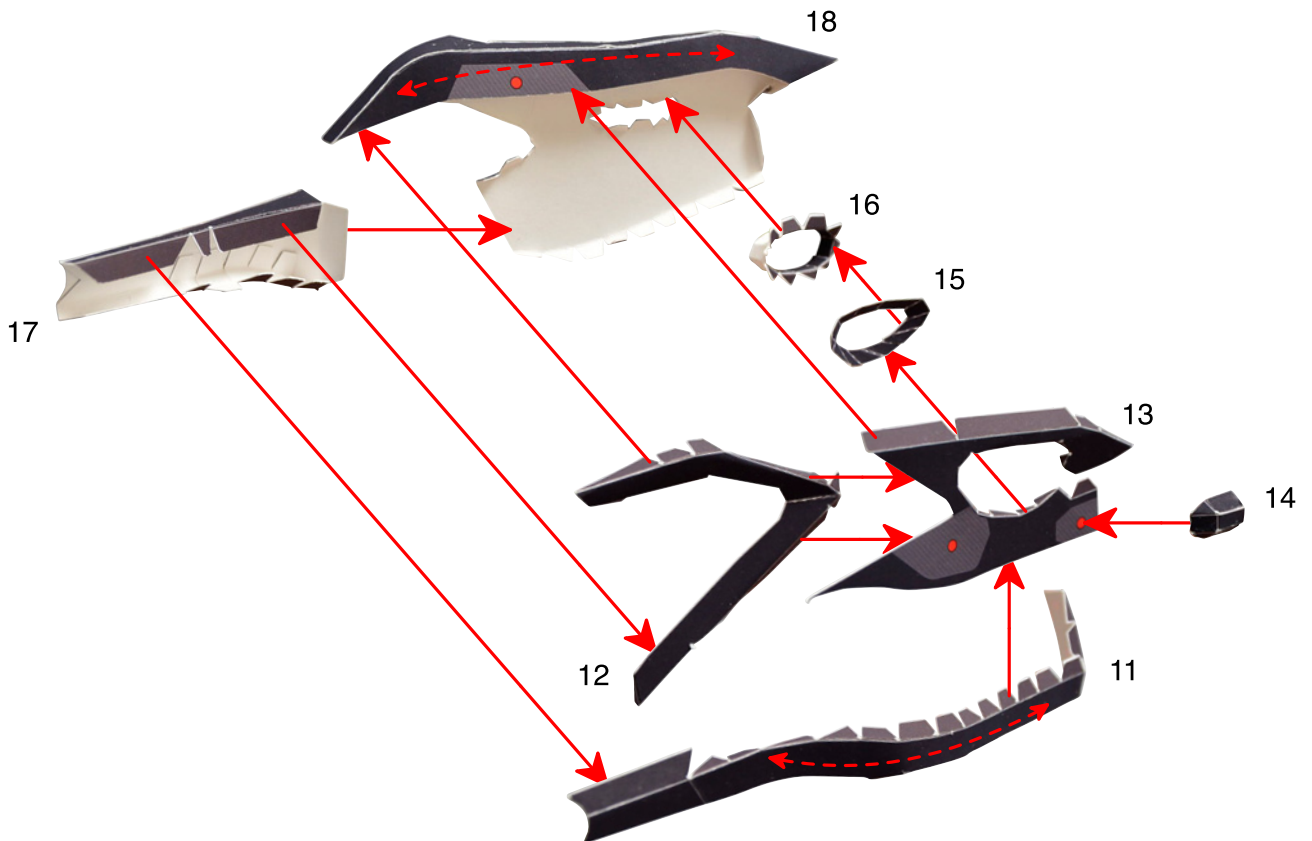

Please refer to the “Basic working method and markings” symbol chart on Page 2 to assemble each part.



Rear Arm C

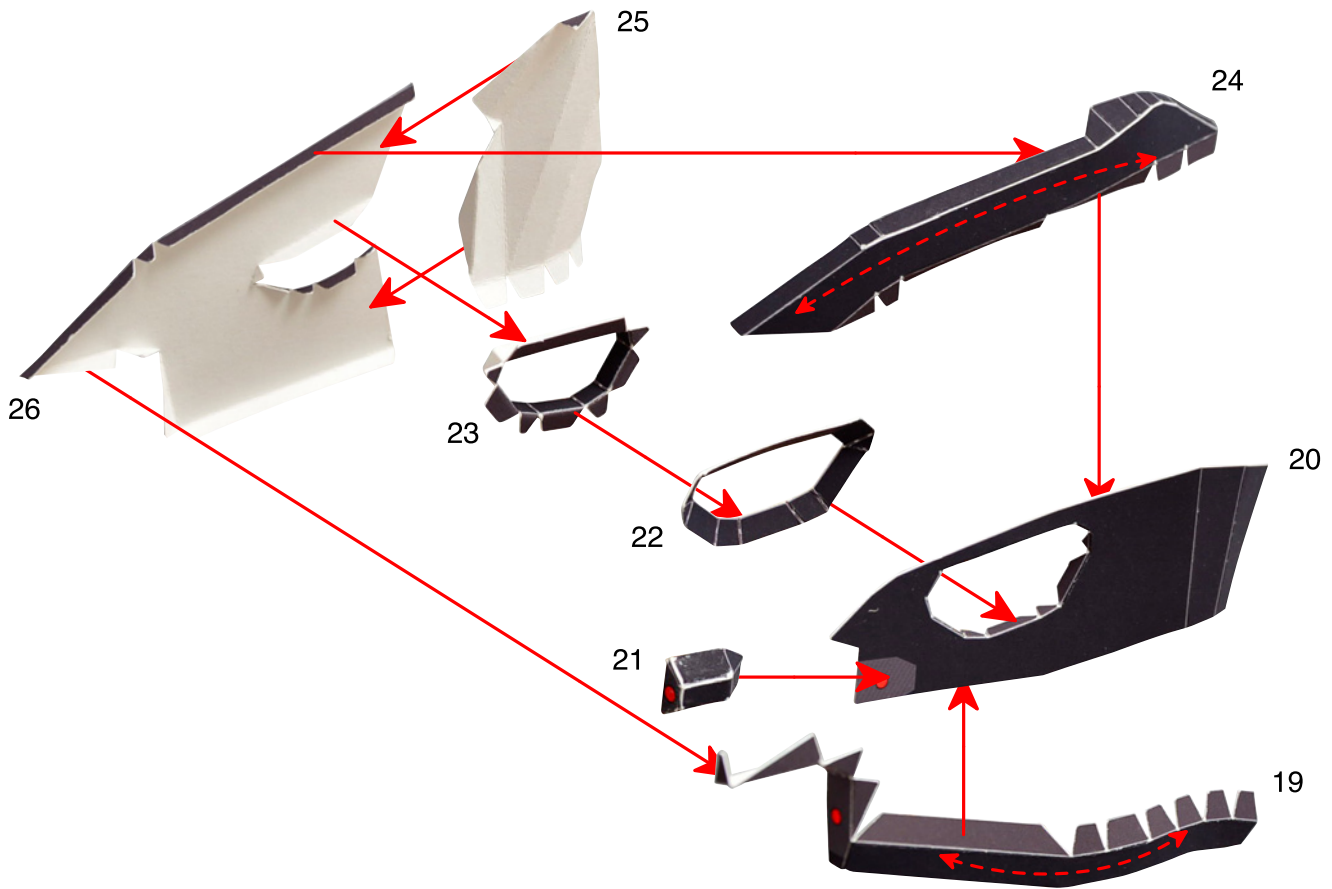

Rear Arm D

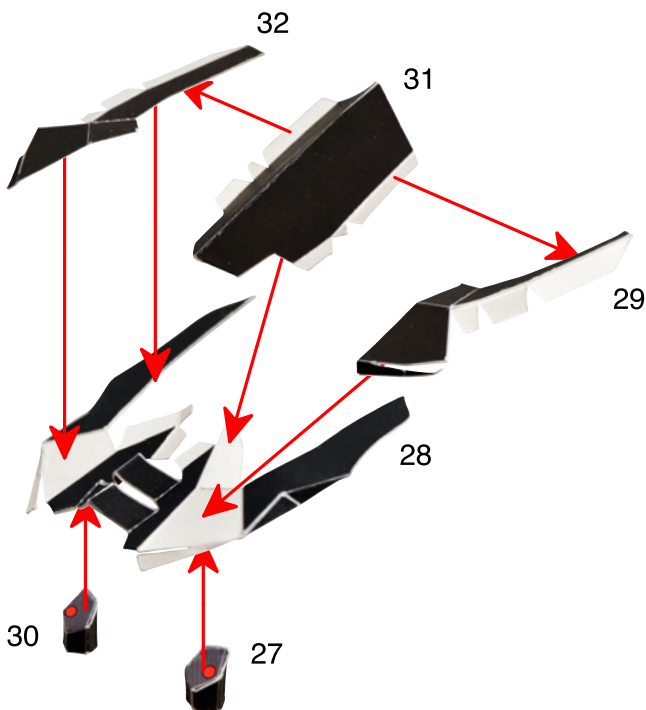

Rear Arm E

*Assemble both sides. The diagram shows the left side. The number inside the () is for the right side.



Please refer to the "Basic working method and markings" symbol chart on Page 2 to assemble each part.



Rear Arm F

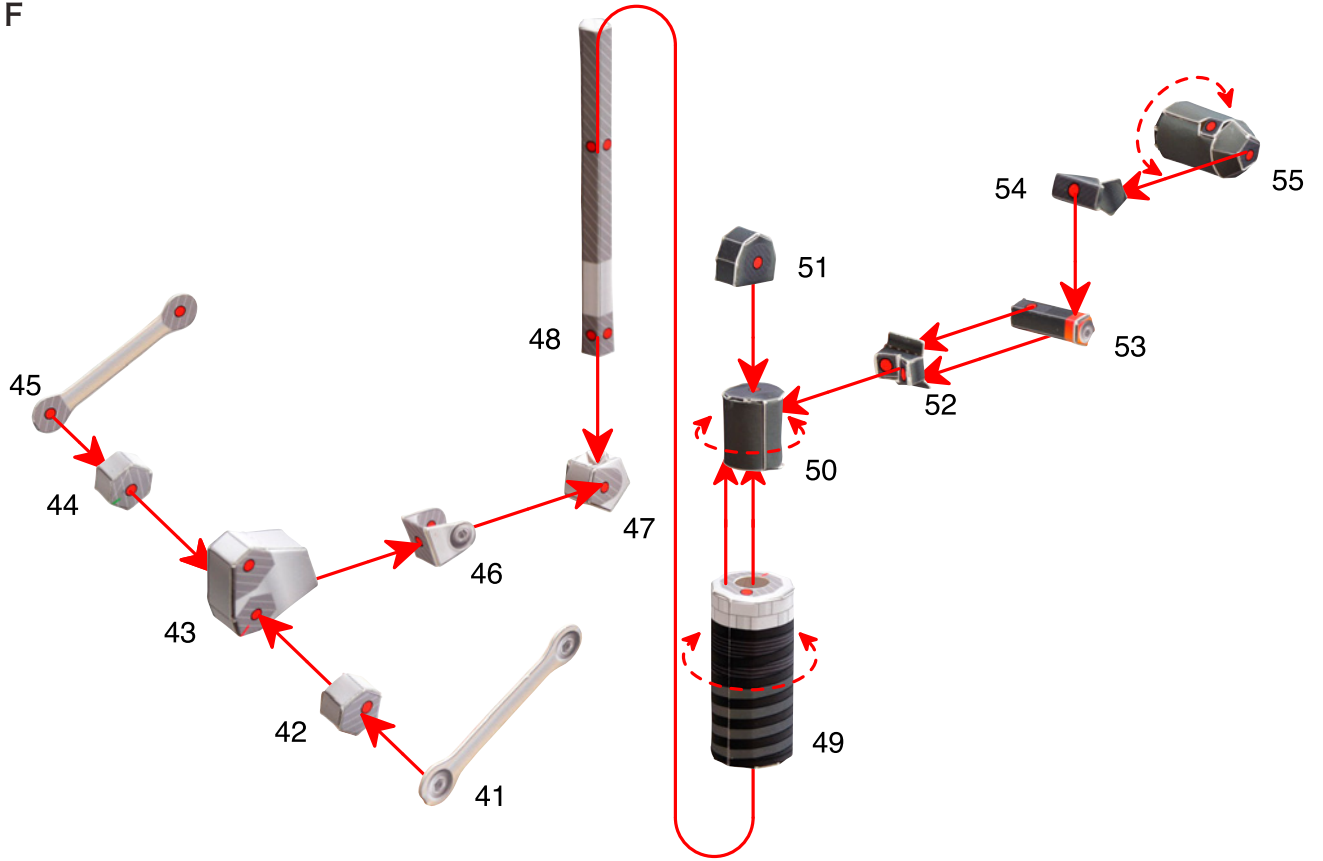

Rear Arm G

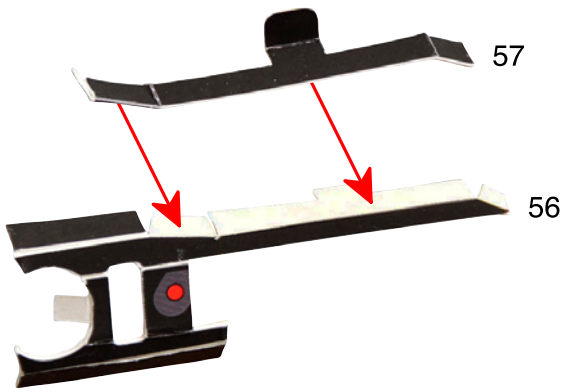

Rear Arm H



Rear Arm I



Please refer to the "Basic working method and markings" symbol chart on Page 2 to assemble each part.

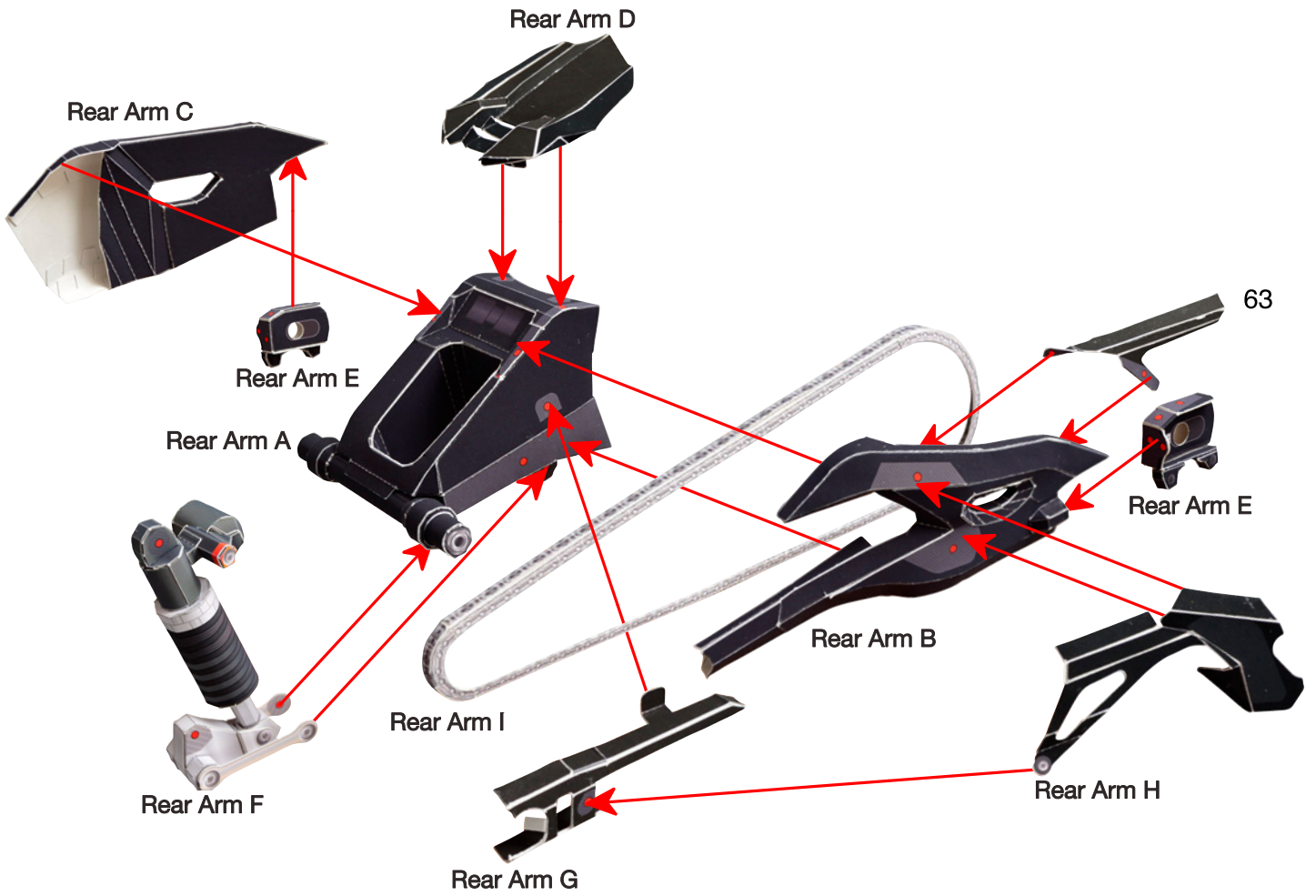

〈 Reference photo 〉



3 Assembly of the Seat

Please refer to the "Basic working method and markings" symbol chart on Page 2 to assemble each part.

Fold or Curve

Glue

Insert

Gluing surfaces

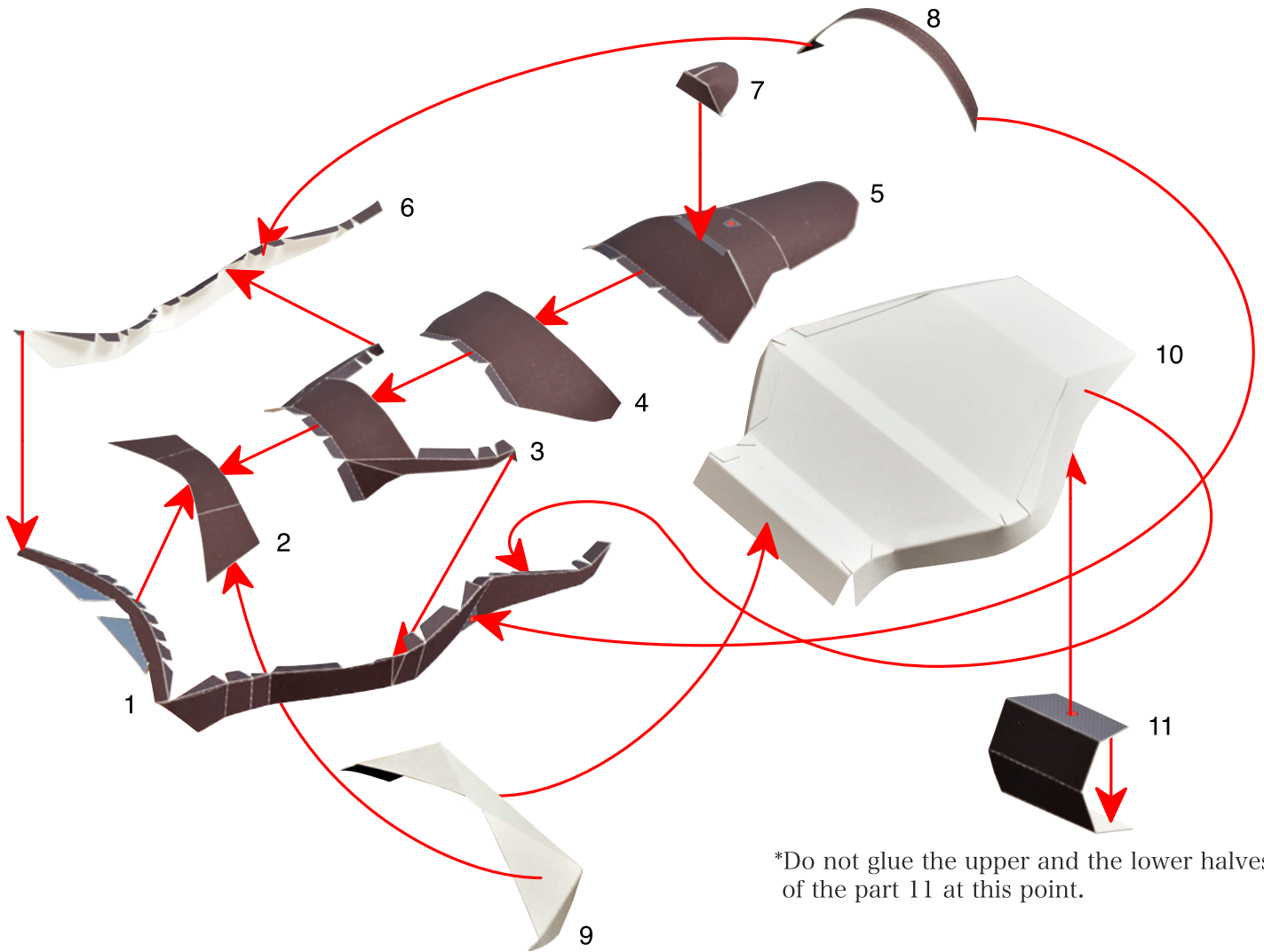

*Do not glue the upper and the lower halves of the part 11 at this point.

〈 Reference photo 〉



3 Assembly of the Seat Cowl 1

Please refer to the "Basic working method and markings" symbol chart on Page 2 to assemble each part.

 Fold or Curve

 Glue

 Insert

 Gluing surfaces

Seat Cowl 1A

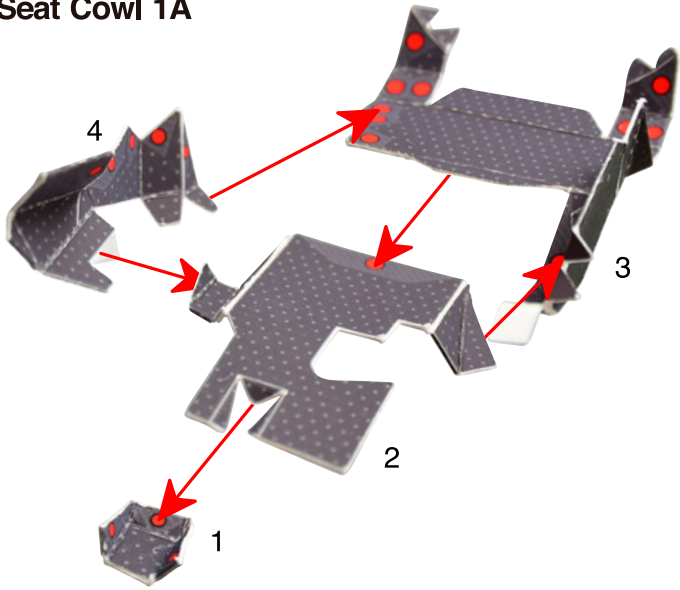

Seat Cowl 1B

*Assemble both sides. The diagram shows the left side. The number inside the () is for the right side.

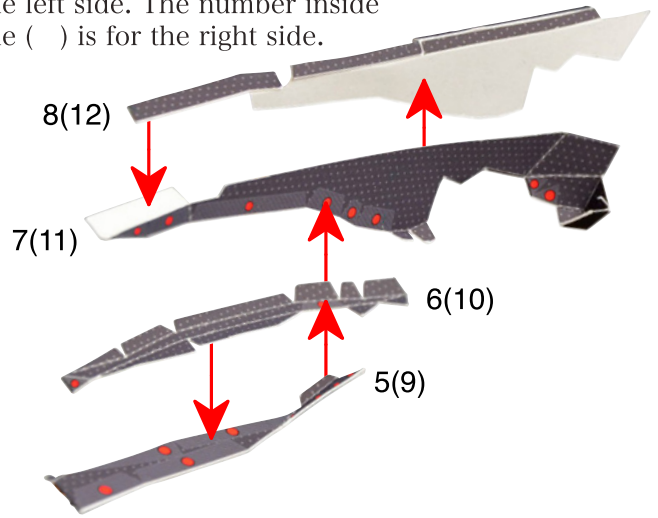

Seat Cowl 1C

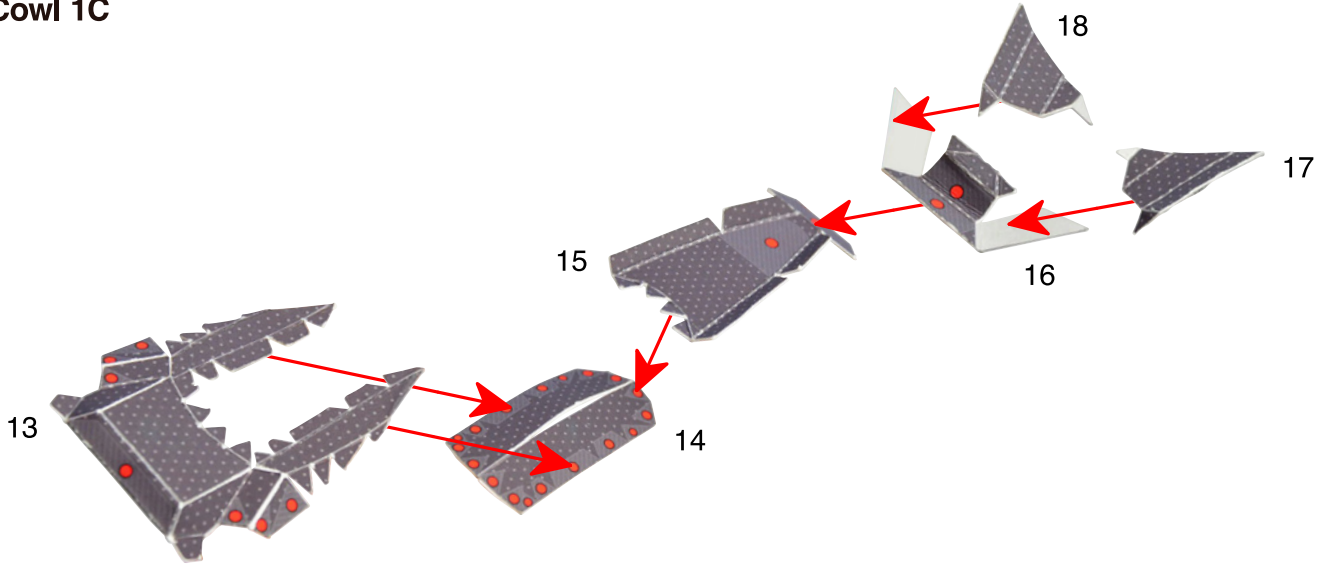

Seat Cowl 1D

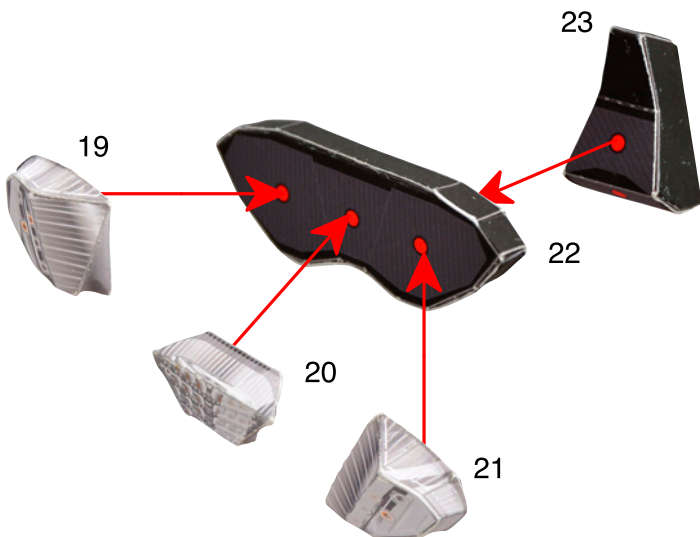

Seat Cowl 1E

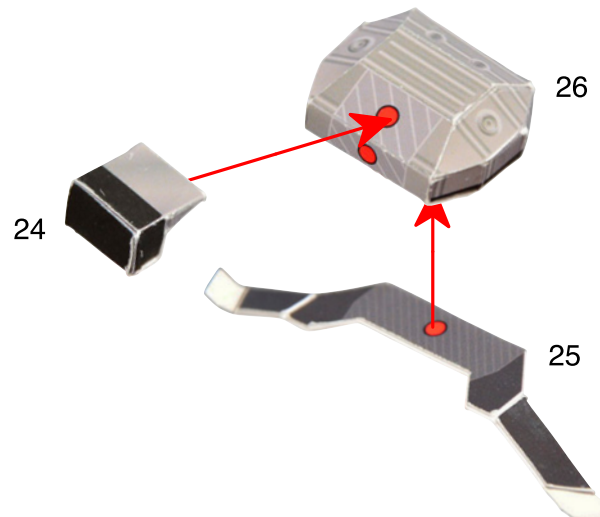

Please refer to the "Basic working method and markings" symbol chart on Page 2 to assemble each part.

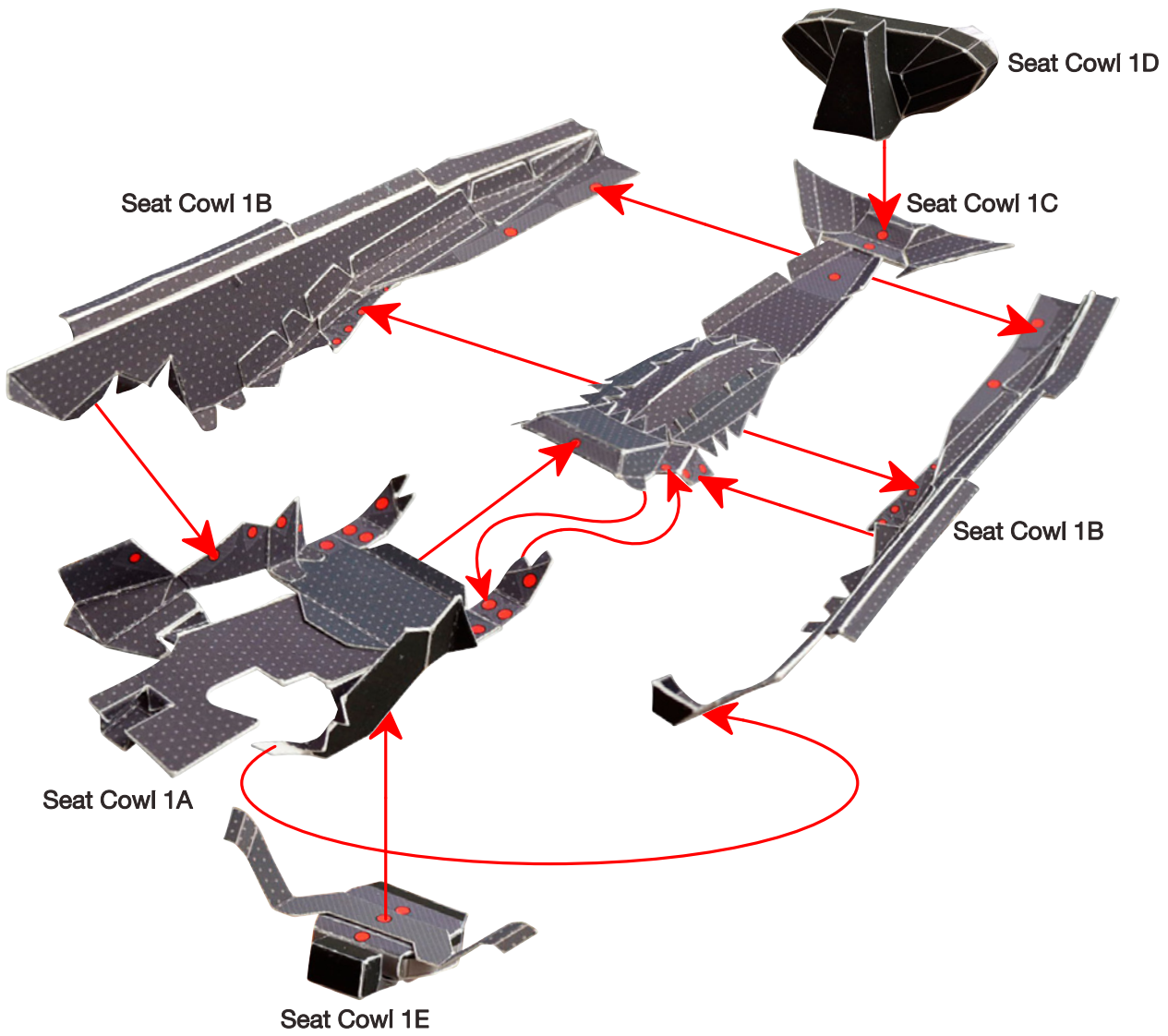

< Reference photo >



3 Assembly of the Seat Cowl 2

Please refer to the "Basic working method and markings" symbol chart on Page 2 to assemble each part.



Seat Cowl 2A

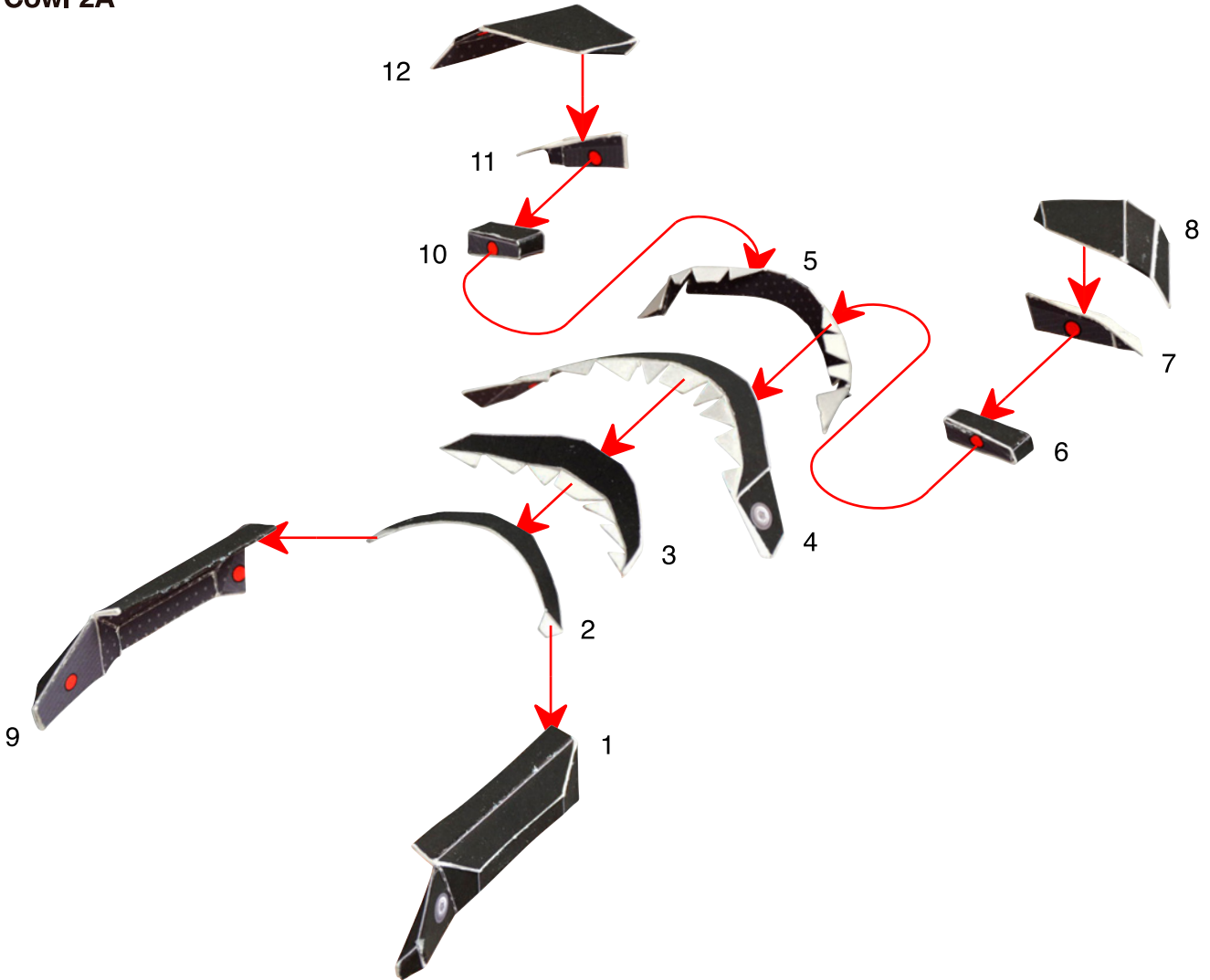

Seat Cowl 2B

*Assemble both sides. The diagram shows the left side. The number inside the () is for the right side.

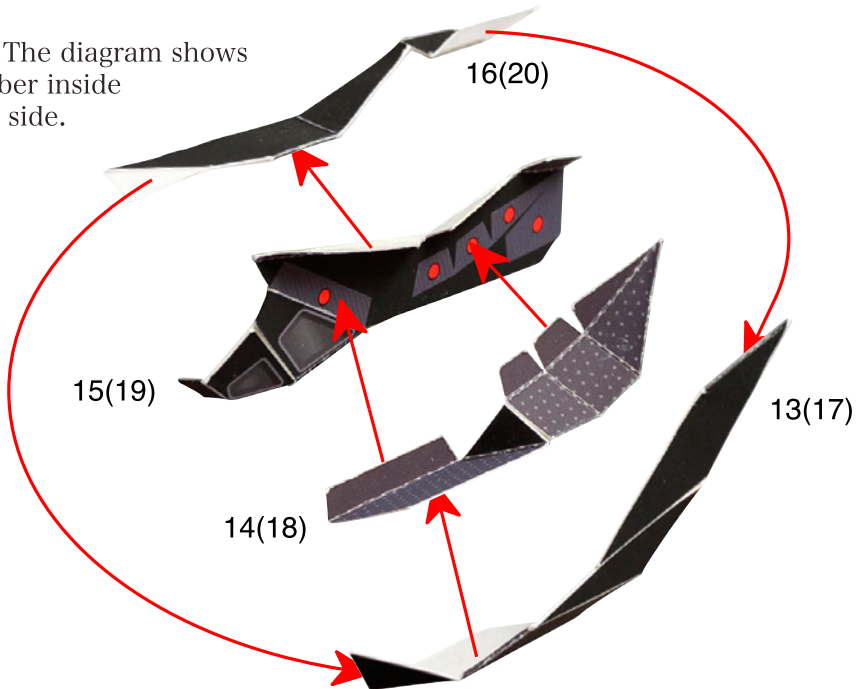

Please refer to the “Basic working method and markings” symbol chart on Page 2 to assemble each part.

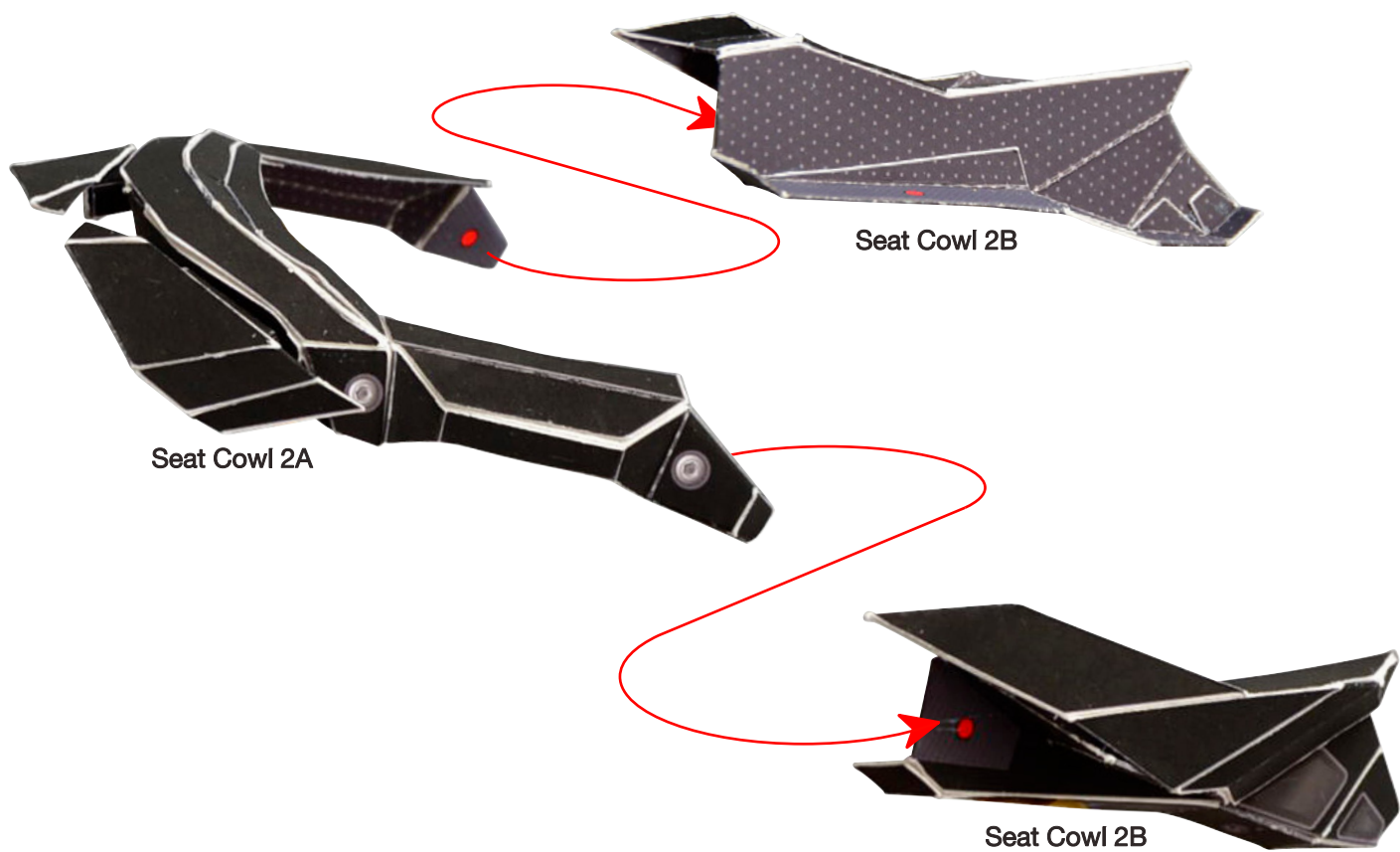

〈 Reference photo 〉



3 Assembly of the Taillight

Please refer to the "Basic working method and markings" symbol chart on Page 2 to assemble each part.

 Fold or Curve

 Glue

 Insert

 Gluing surfaces

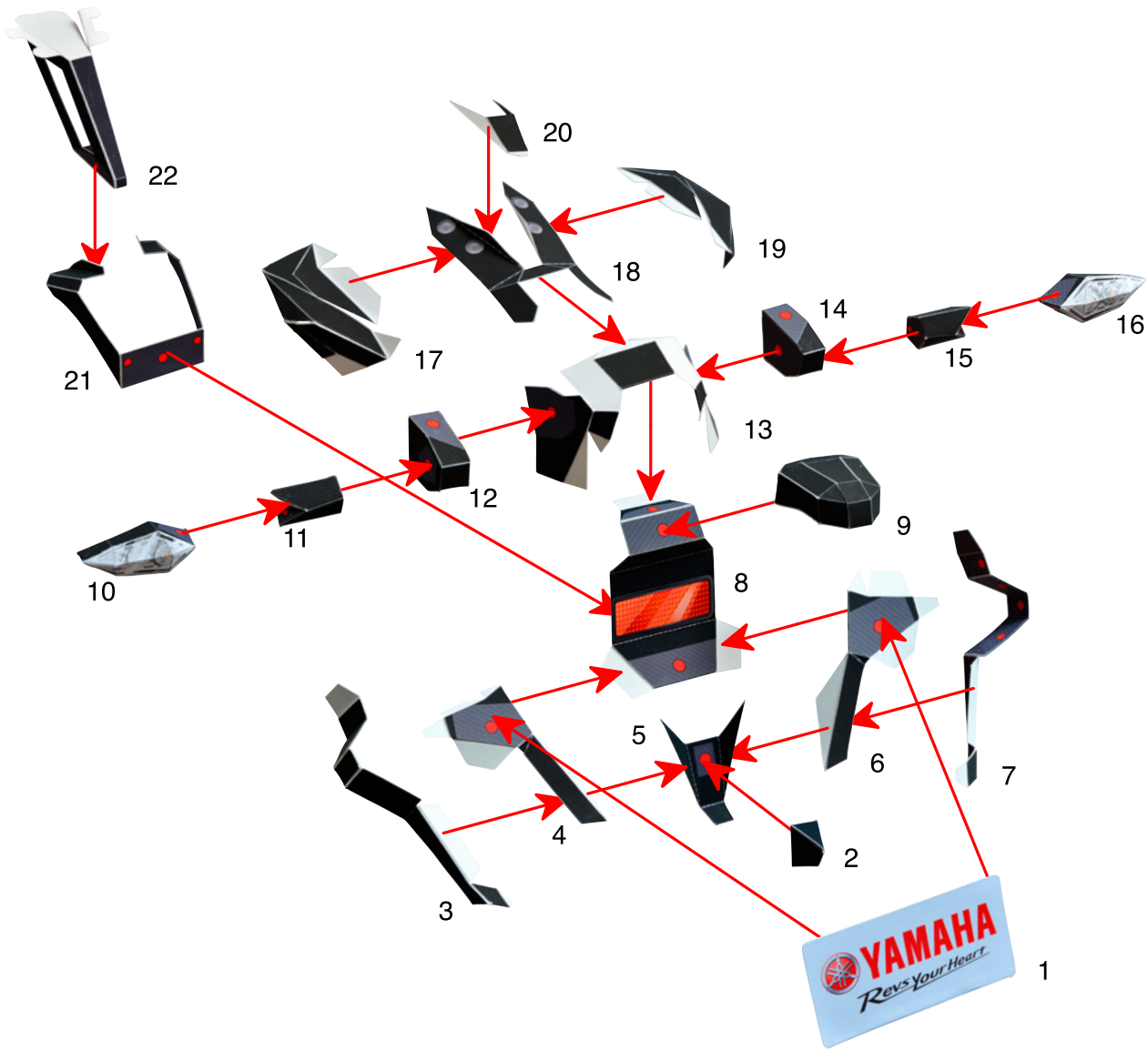

〈 Reference photo 〉



3 Assembly of the Left footrest & Right footrest

Please refer to the "Basic working method and markings" symbol chart on Page 2 to assemble each part.

 Fold or Curve

 Glue

 Insert

 Gluing surfaces

Left footrest

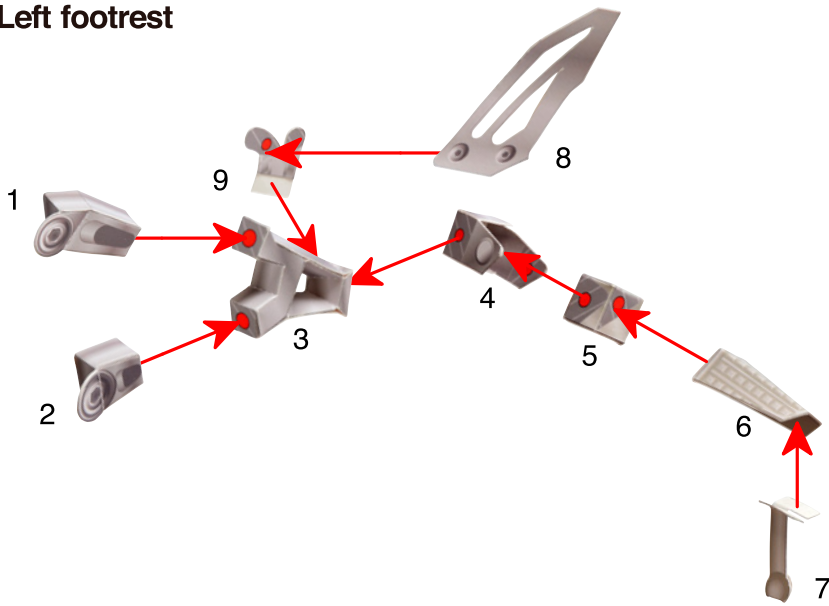

⟨ Reference photo ⟩



Right footrest

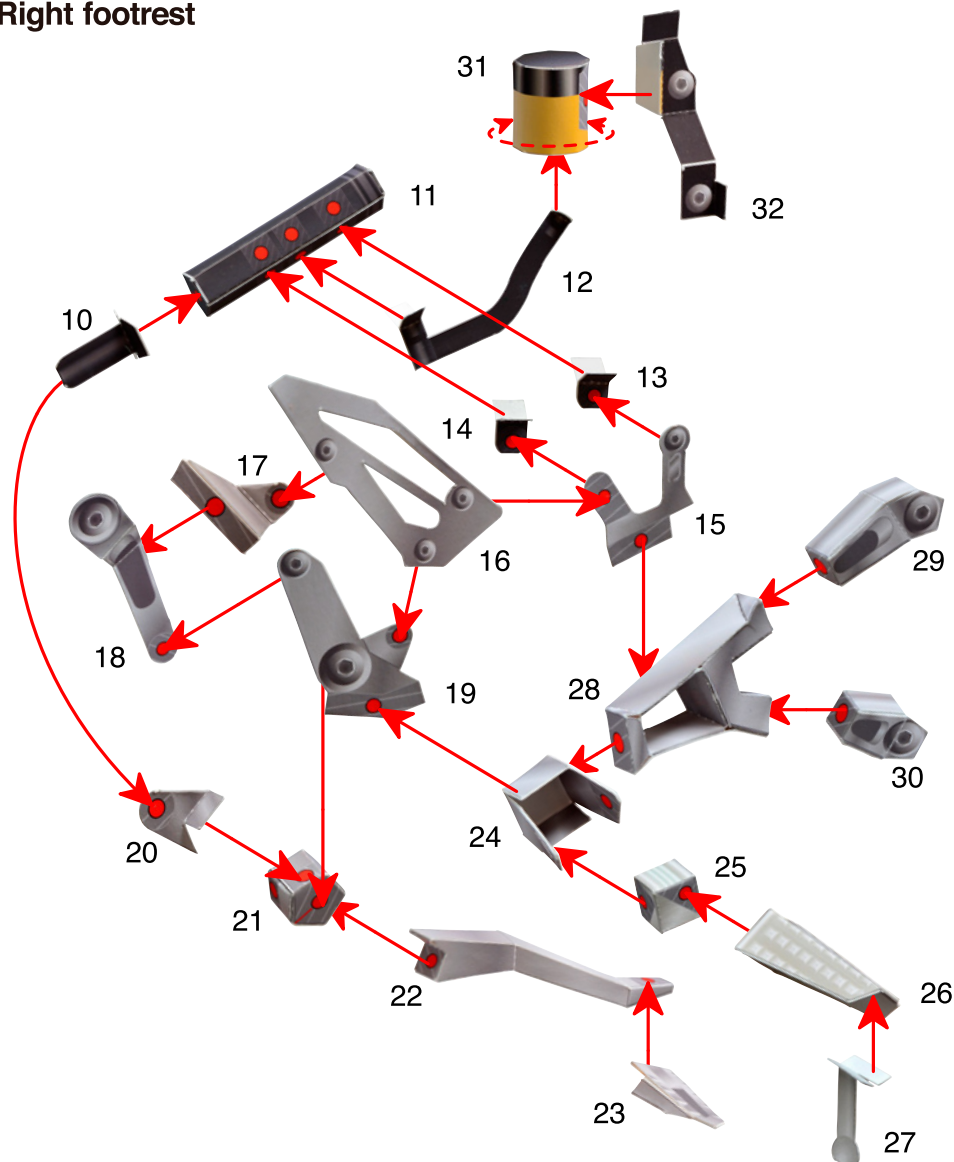

⟨ Reference photo ⟩

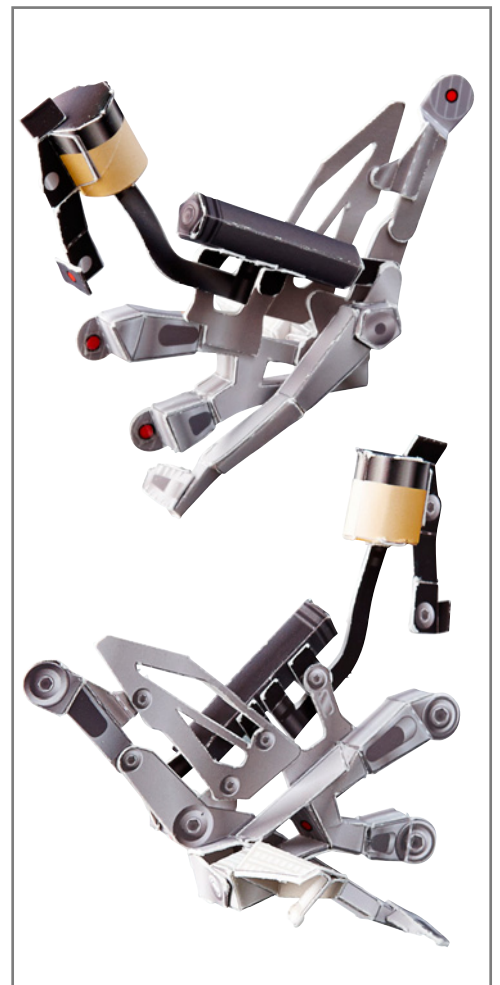

3 Assembly of the Side Stand & Rear footrests

Please refer to the "Basic working method and markings" symbol chart on Page 2 to assemble each part.



Side Stand

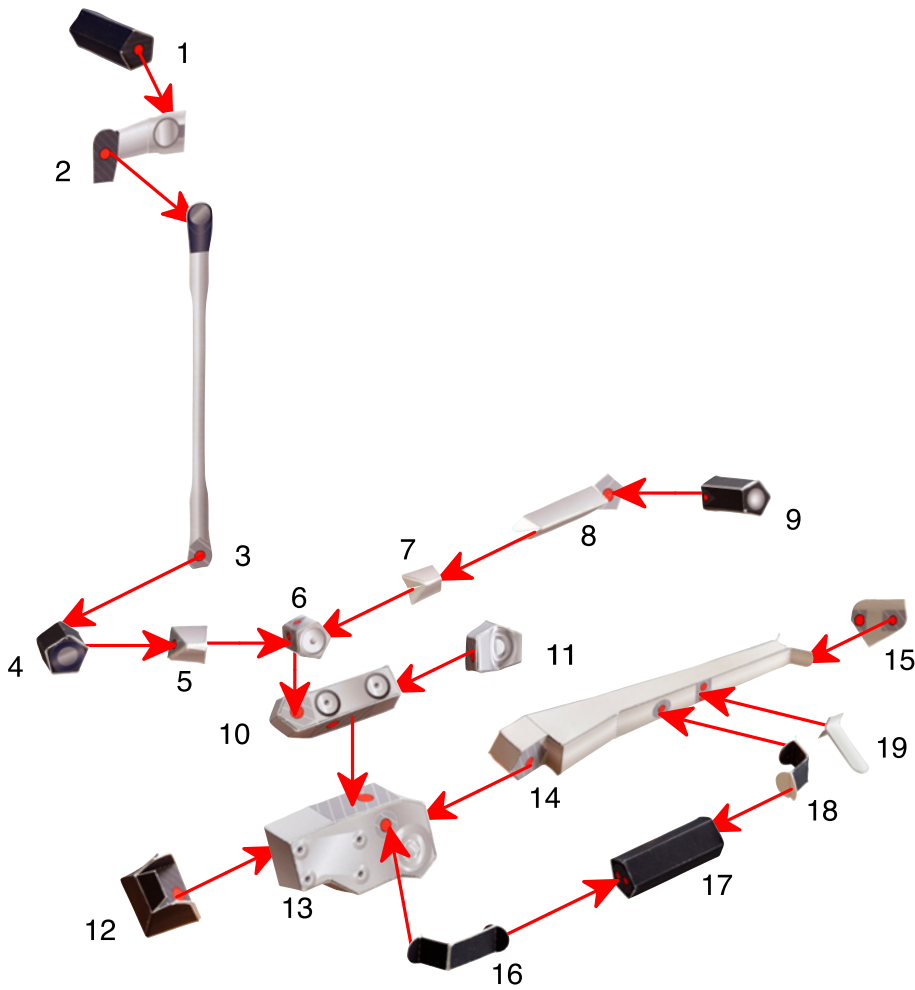

〈 Reference photo 〉



Rear footrests

*Assemble both sides. The diagram shows the left side. The number inside the () is for the right side.

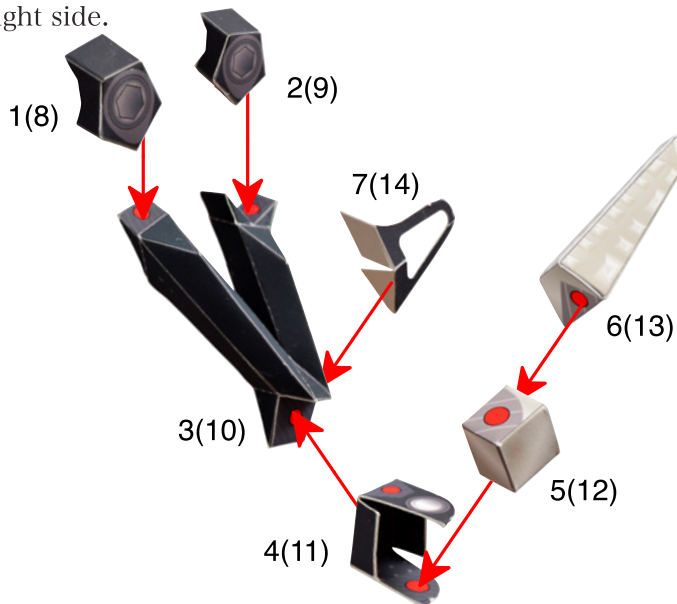

〈 Reference photo 〉

